



# enviropo

## Single Span Assembly Instructions

INS475

# Thank you for purchasing your EnviroPro Single Span polytunnel

Before you begin:

- Check that all parts are present
- Read the instructions

## Your safety matters

Please take care during construction and follow all guidance provided.

## Need help?

☎ 01282 873 120

✉ info@npstructures.co.uk

🌐 northernpolytunnels.co.uk



### Important

Failure to follow these instructions may compromise the structural integrity of your polytunnel.

NP Structures Ltd accepts no liability for damage resulting from misuse or failure to follow instructions.



Drawings are not to scale.



## Tools Required

Stakes/Pegs  
Spirit Level  
Spade  
Tape Measure  
Marker Pen  
String  
Hammer  
Stanley Knife  
Battery Drill  
Angle Grinder  
Wire Cutters  
Spanners  
Gloves  
Goggle/Eye Protection/PPE  
G-clamp

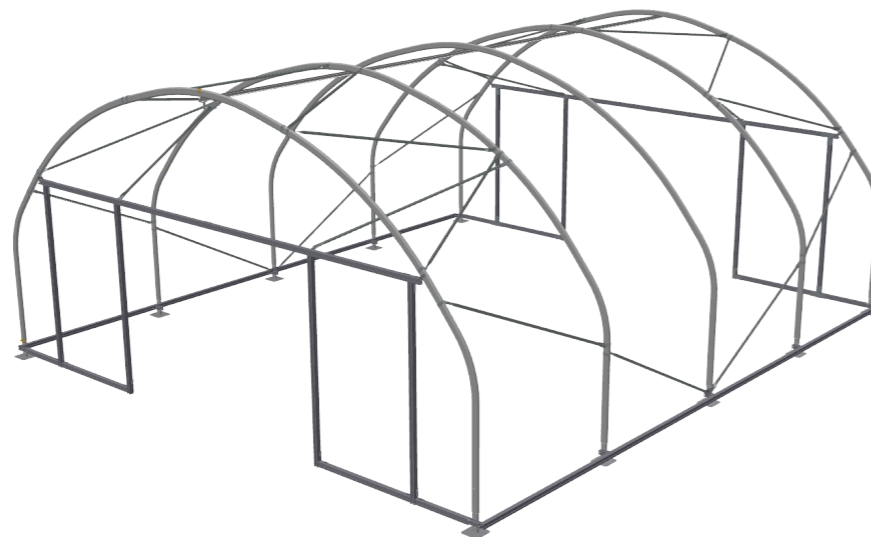

Code	Description
HNP100	Hex Nut Plain M10
HNN600	Hex Nut Nylock M6
HNN100	Hex Nut Nylock M10
HNF600	Hex Nut Flanged M6
HNF800	Hex Nut Flanged M8
HNF100	Hex Nut Flanged M10
CSB840	Cup Square Bolt M8 x 40mm
CSB850	Cup Square Bolt M8 x 50mm
CSB865	Cup Square Bolt M8 x 65mm
CSB880	Cup Square Bolt M8 x 80mm
CSB815	Cup Square Bolt M8 x 140mm
HBT607	Hex Bolt M6 x 70mm
HBT107	Hex Bolt M10 x 60mm
HBT811	Hex Bolt M8 x 110mm
HBT114	Hex Bolt M10 x 110mm
HSS101	Hex Set Screw M10 x 20mm
HSS104	Hex Set Screw M10 x 35mm
BHS602	Button Head Screw M6 x 16mm
ECB32	Exhaust Clamp Bracket 32mm
ECB42	Exhaust Clamp Bracket 42mm
ECB50	Exhaust Clamp Bracket 50mm
SAR107	Sleeve Anchor M10 x 100mm (Concrete bolt)

## Contents

### Foundations 6

Planning Foundations .....	6
Foundation Measurements .....	6
Installing Base Plate Foundations .....	9
Installing Concrete Foundations .....	10
Digging Holes For End Frame .....	11

### Steel Box Profile Overview 12

Familiarise Yourself With The Steel Box Profile .....	12
Using Cotters .....	12

### Base Rails 13

### Hoops 17

Hoop Assembly .....	17
Install Ridge Bars .....	18

### Bracing & End Frame 19

Brace Bar Configuration .....	19
Fitting Brace Bars .....	20
Gable End Frame Configuration .....	22
Fitting Gable End Frame .....	26
Install Lintel Brace Bar .....	34

### Crop Bars 36

Crop Bar I Hanger Configuration .....	36
Crop Bar V Hanger Configuration .....	38
Crop Bar W Hanger Configuration (Optional Haunches) .....	40

### Side Rails 42

### Curtain 44

Installing Curtain .....	44
Manual Winder .....	45
Motorised Winder .....	46

### Side Vent Skirt to Net 48

### Wiggle Wire Channel Over End Hoops 50

### Sliding Door 51

### Above Door Louvre 52

Assemble Louvre .....	52
Cover Louvre .....	53
Attach Louvre to H Frame .....	54
Connect Rack and Pinion .....	54

### Covering 56

Applying Anti Hot Spot tape .....	56
Prepare Polythene .....	56
Covering Polytunnel With Wiggle Wire Over Hoop .....	57
Covering Polytunnel Pleating Gable Ends Method .....	59

Tools needed: tape measure, string, spirit level, markers/canes

### Planning Foundations

Use the diagram on the next page to lay out your foundations accurately

Choose a level, even site where possible. Avoid stony ground, especially if trenching in the polythene, as this may cause damage. Allow at least 1 metre of working space around the structure.

#### To mark out the site

- Use string (thin polypropylene twine) and pegs to plan out your foundation positions
- Use the table provided to check the diagonal and hoop spacing measurements — this ensures your layout is square.
- Mark the stringline at each hoop position and place a ground tube at each mark.

**i** The diagram is for illustrative purposes only. Repeat the layout process according to the number of hoops you have ordered.

**i** All measurements are taken from the centre of the foundation.

### Foundation Measurements

Tunnel Width	A - WIDTH Centre to Centre	B - HOOP SPACING Centre to Centre	H - DIAGONAL Centre to Centre
5 metres	5000mm	2500mm	7071mm
6 metres	6000mm	2500mm	7810mm
7 metres	7000mm	2000mm	8062mm
8 metres	8000mm	2000mm	8944mm
9 metres	9000mm	2000mm	9849mm

N = last hoop

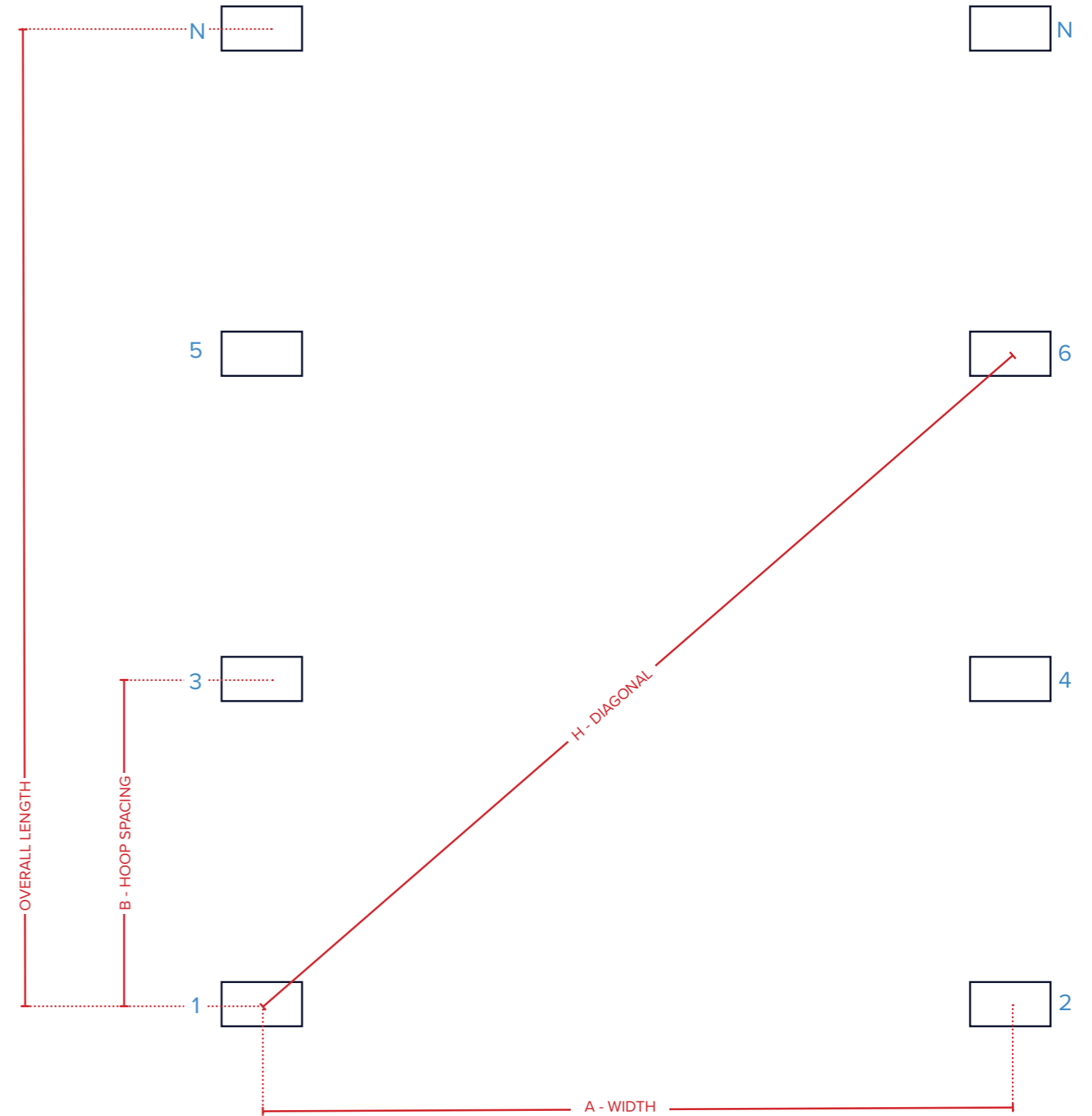

**Method**

You may wish to mark out your foundation placement with markers or stakes before positioning the actual foundations. For “Foundation Measurements” see page 6.

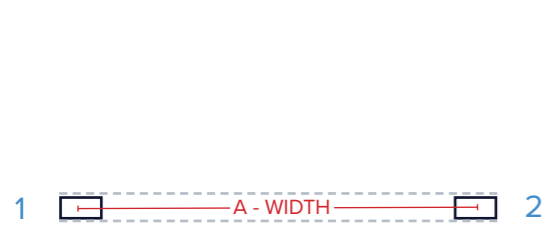

1. Position foundations 1 and 2.  
Check **A - WIDTH** is correct.  
Check alignment of the two foundations.

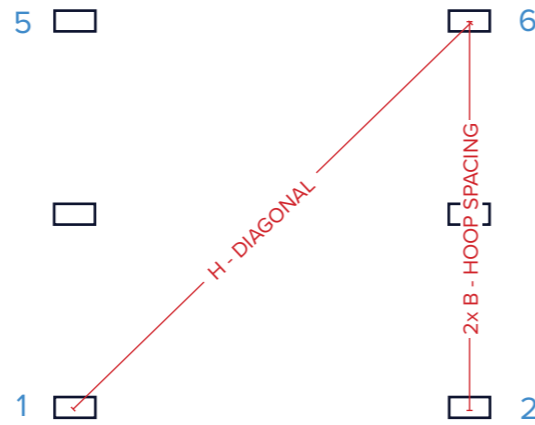

2. Position foundation 6  
Check **H - DIAGONAL** is correct.  
Check **2x B - HOOP SPACING** is correct.  
Repeat for foundation 5.

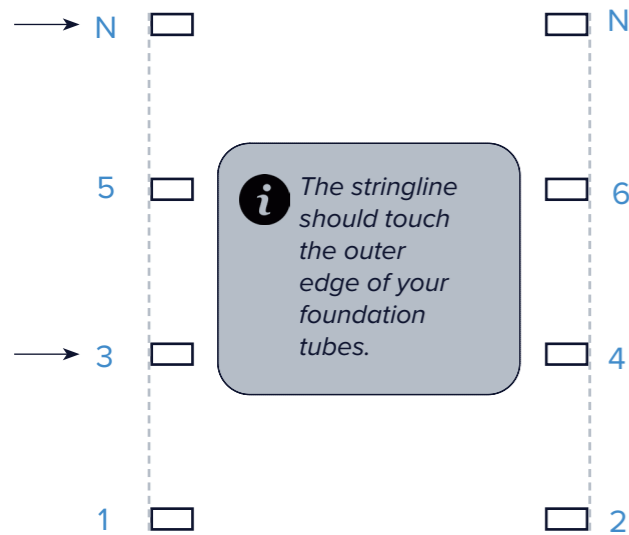

3. Stringline the length of the tunnel from 1 and 2 to last foundations (**N**).

Use the stringline to help you place your last foundations (**N**) as well as any other foundations e.g. 3 and 4.

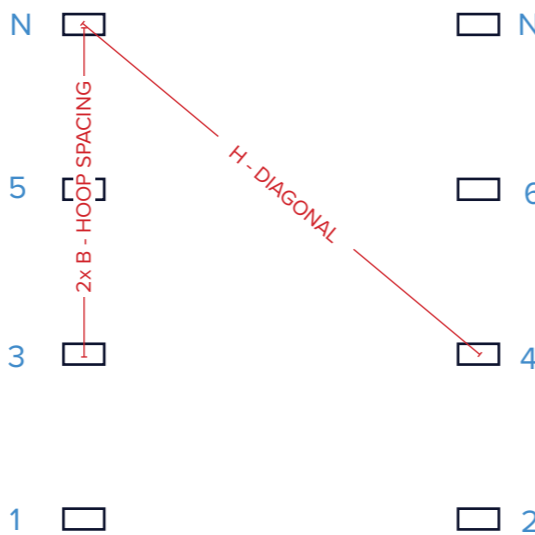

4. Check alignment of the far end of your polytunnel:

Check **H - DIAGONAL** is correct.  
Check **2x B - HOOP SPACING** is correct.  
Repeat on each end foundation.

**Installing Base Plate Foundations**

**1. Position the Base Plates**

Use your string line as a guide. For “Foundation Measurements” see page 6.

**2. Mark and Drill**

Mark the position of the four fixing holes on each base plate.

Drill four holes per plate: **12mm diameter x 100mm** deep into the concrete.

Vacuum out dust from each hole to allow full depth insertion of the anchor bolts.

**3. Fix in Place**

Insert the sleeved anchor bolts through the base plate and into the holes.

Hammer them fully in, then tighten the bolts securely.

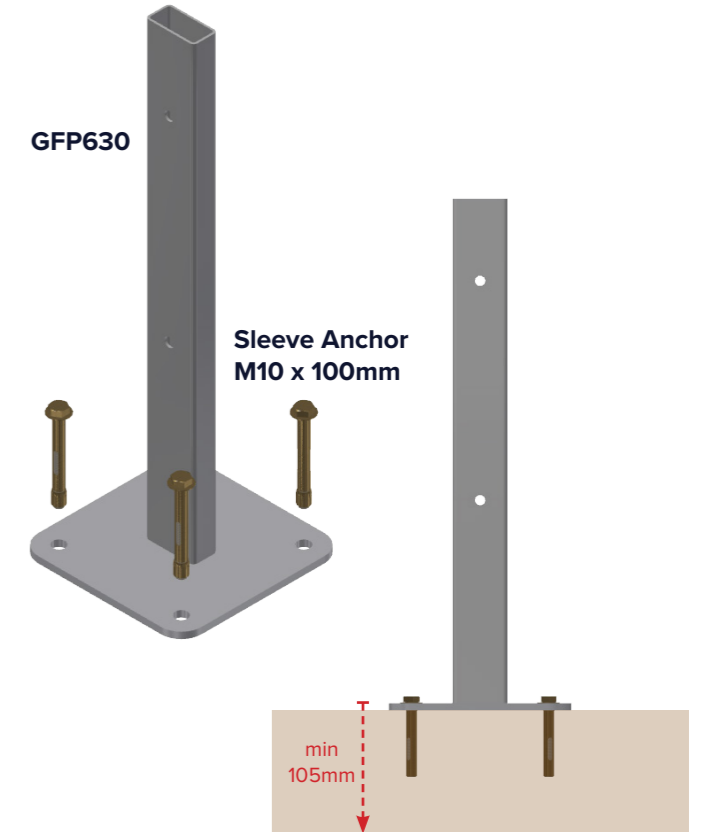

**!** It is essential that the anchor bolt sleeves are fully inserted to ensure a secure fit.

For “Installing Concrete Foundations” see page 10

## Installing Concrete Foundations

### 1. Dig the Foundation Holes

Follow the diagram for hole size. For "Foundation Measurements" see page 6.

Ensure holes are evenly spaced and aligned.

### 2. Pour Concrete into Each Hole

Recommended: ready-mix GEN3, 20 N/mm<sup>2</sup>, 60mm slump.

### 3. Set the Ground Tubes (GFT630) in Concrete

Insert a concrete bar into the bottom hole of the foundation, then position the ground tubes in the concrete and align them using a string line - they must be straight and level.

**i** Ground level is etched onto ground tube. Arrow pointing up.

### 4. Allow Concrete to Set

Let the concrete cure for at least 48 hours (longer in cold or wet weather).

### 5. Mark the End Frame Lines

Once set, run a string line across the inside face of the first and last hoop to mark the lines for the end frame uprights.

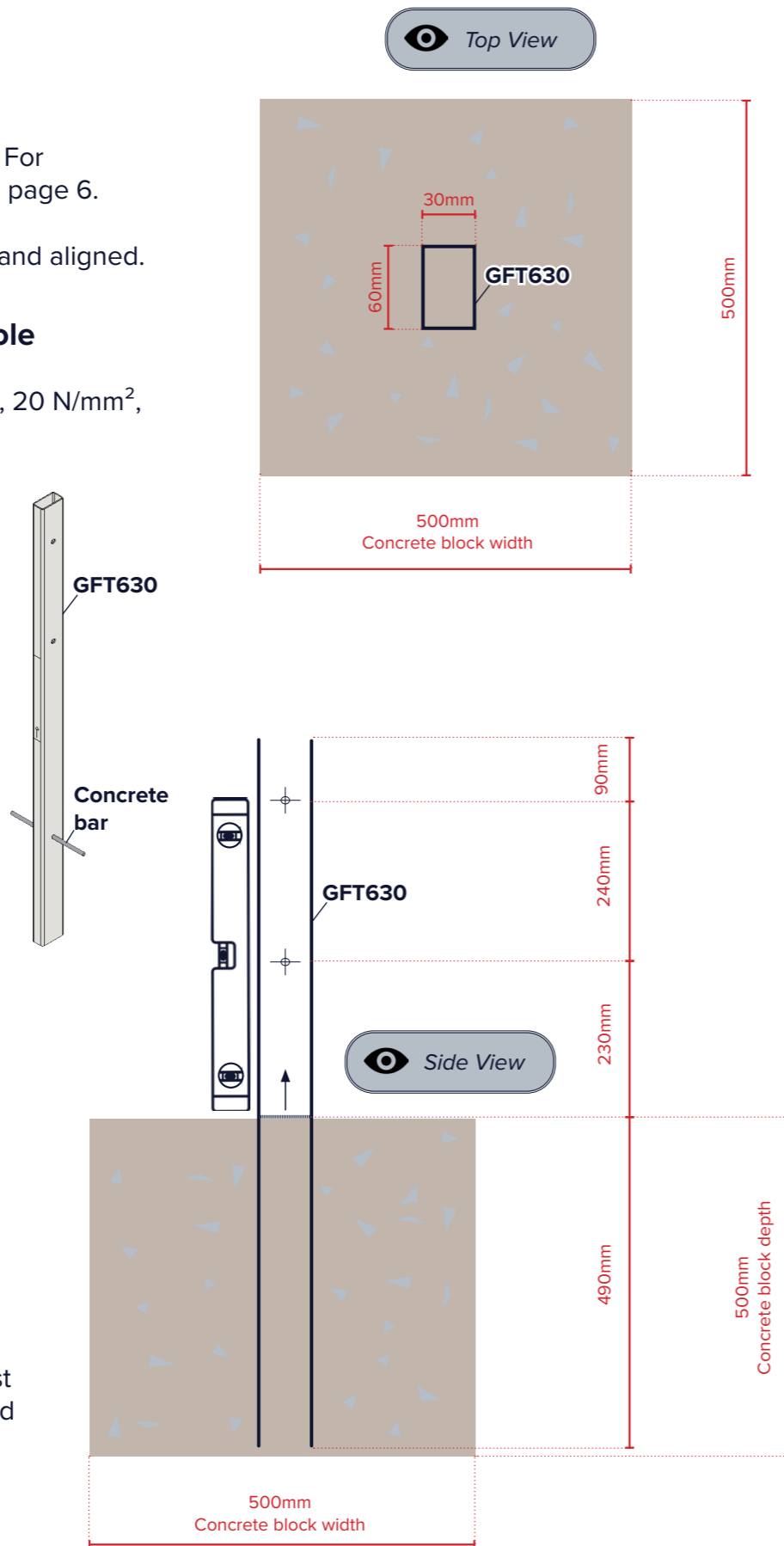

## Digging Holes For End Frame

At each gable end, mark the post positions as shown in the diagram. Then dig:

**!** For 5m wide tunnels, **do not** dig outer 300mm<sup>2</sup> holes.

- Two 300mm<sup>2</sup> holes for the door frame posts
- Two 300mm<sup>2</sup> holes for the outer upright posts (not required on 5m tunnels)

All holes should be 300–400mm deep.

N = last hoop

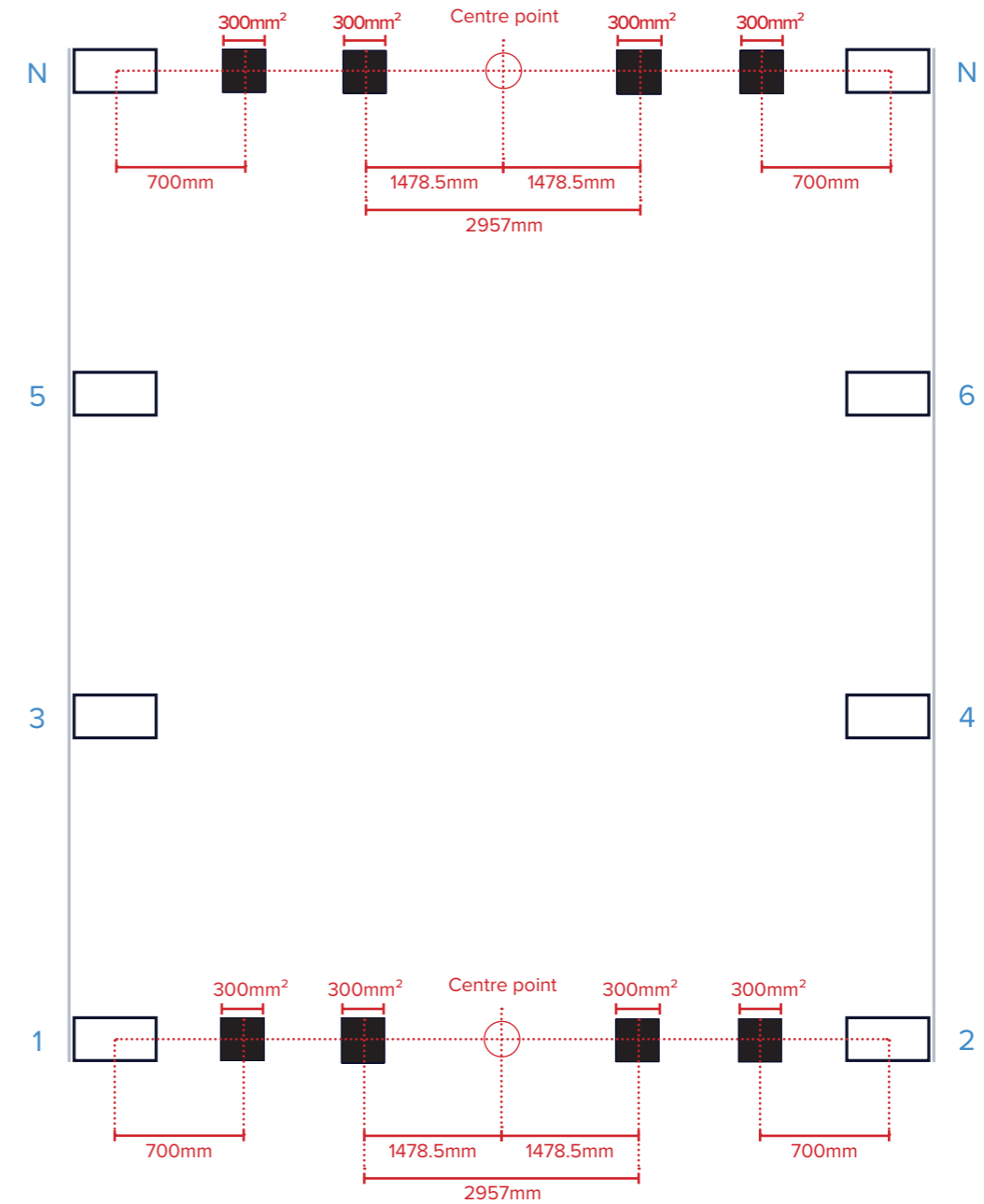

### Familiarise Yourself With The Steel Box Profile

This steel box profile (WBP) is used throughout the construction of your EnviroPro Single Span Polytunnel, including end frames, base rails, side rails. It is useful to familiarise yourself with this profile to avoid confusion.

The top (larger) channel is for wiggle wire which is used for attaching the cover. The bottom (smaller) channel is used to slide M8 bolts with cotter in for fixing brackets.

**The top wiggle wire channel should be on the outside of the tunnel, and the bolts should be on the inside.**

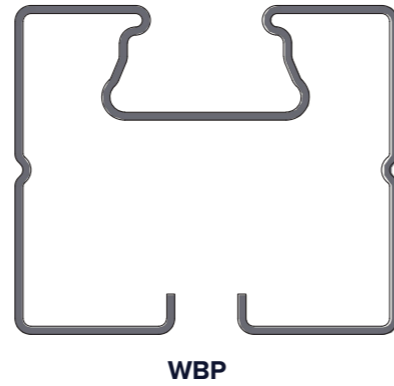

### Using Cotters

Cotters are used throughout for attaching brackets to the steel box profile. Cotters come in various sizes.

#### 1. Assemble cotter, bolts, and bracket

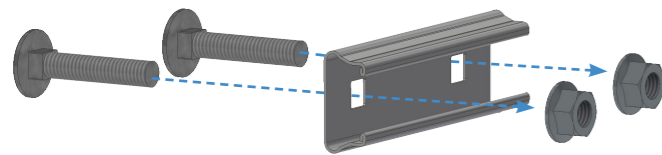

#### 2. Finger tighten cotter

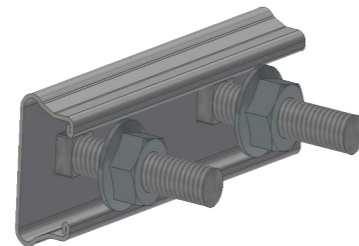

#### 3. Slide cotter and bracket assembly into box profile

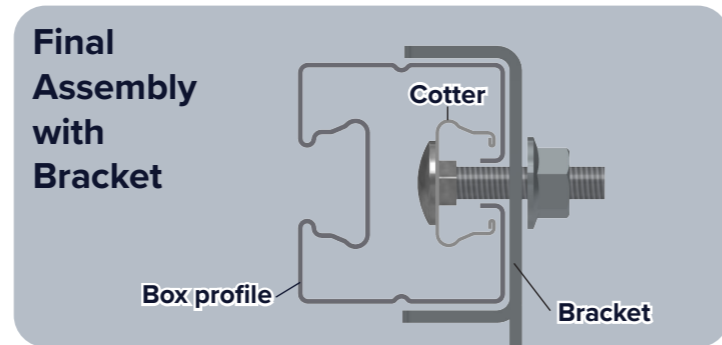
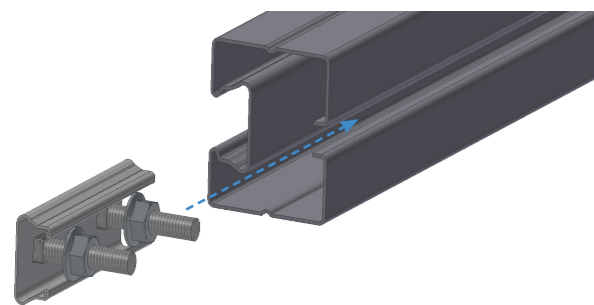

**!** Take note of the cotter positions at each stage of the build.  
**It isn't possible to retrofit cotters**, therefore it is critical that cotters are in position before the section is fitted to the frame.

Pack(s): CSS206, CSS204

### Bracket Assembly

#### Inner Hoop Foundations = a

x2 per hoop

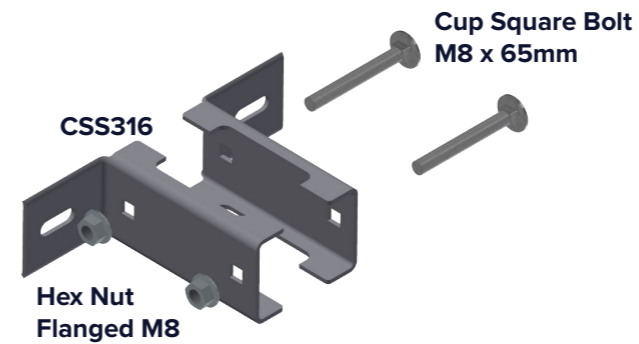

#### End Hoop Foundations = b

x4 total

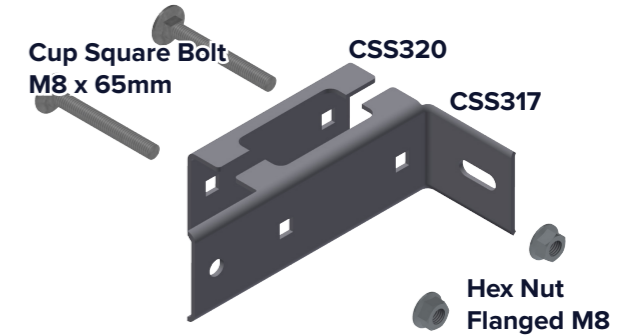

### Bracket Layout

Loosely place parts into position.



For all inner hoop foundations (a)

**i** Leave bolts hand-tightened at this stage.

1. Loosely assemble inner hoop base rail bracket

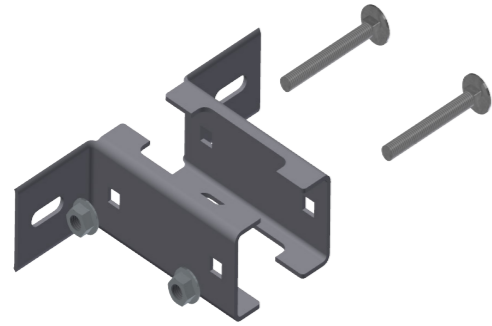

For "Bracket Assembly" see page 13

2. Slide bracket onto inner foundations

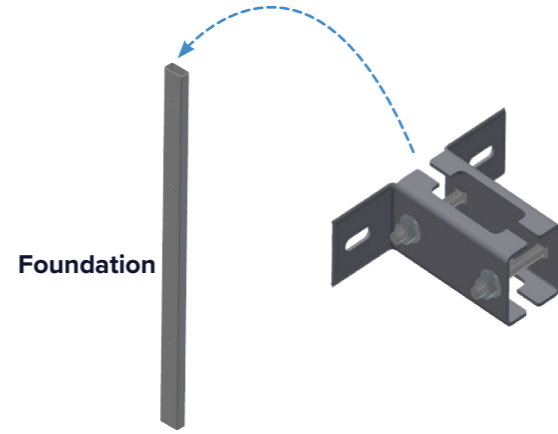

3. Loosely attach cotter

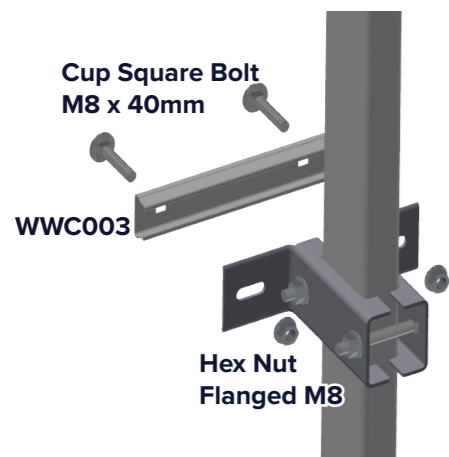

4. Slide base rail onto brackets

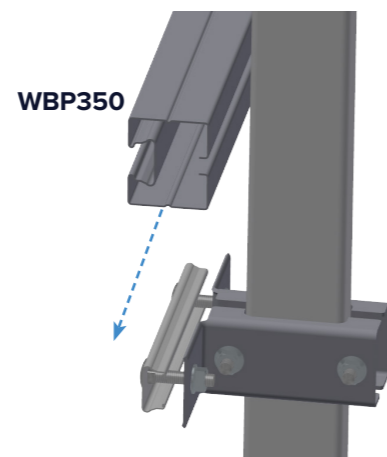

Join base rail profiles when required

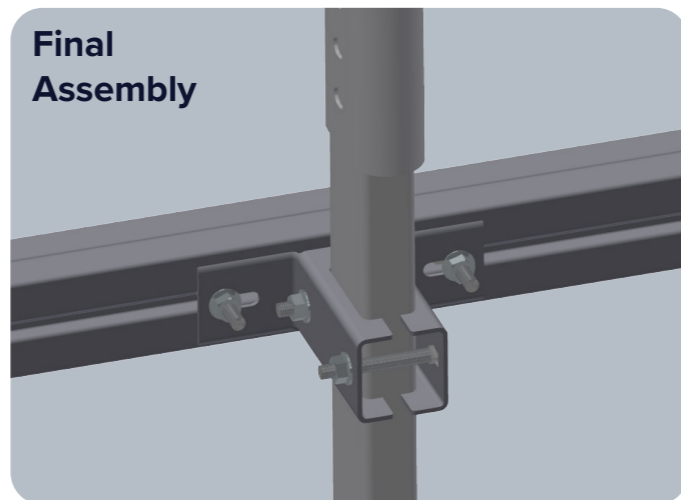
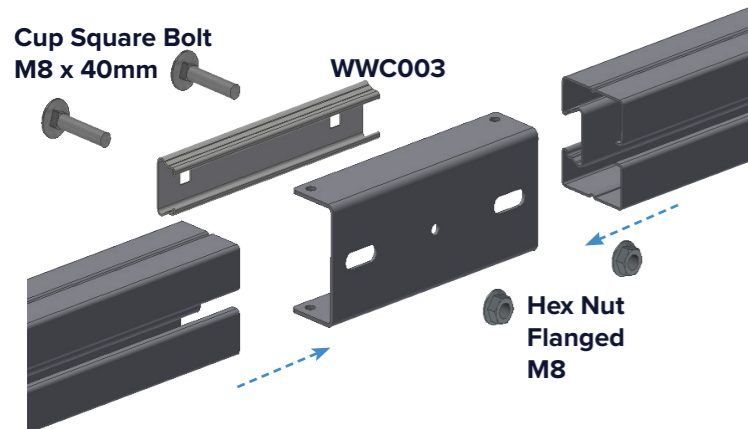

For all end hoop foundations (b)

**i** Leave bolts hand-tightened at this stage.

1. Assemble end hoop base rail bracket

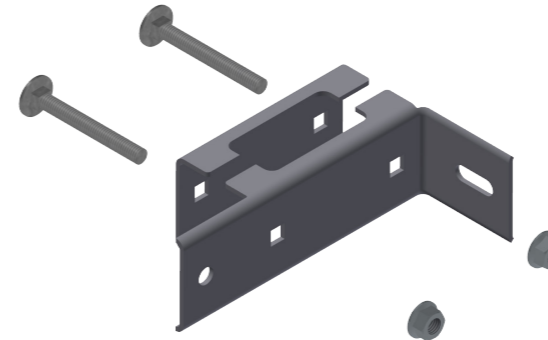

For "Bracket Assembly" see page 13

2. Slide bracket onto end hoop foundations

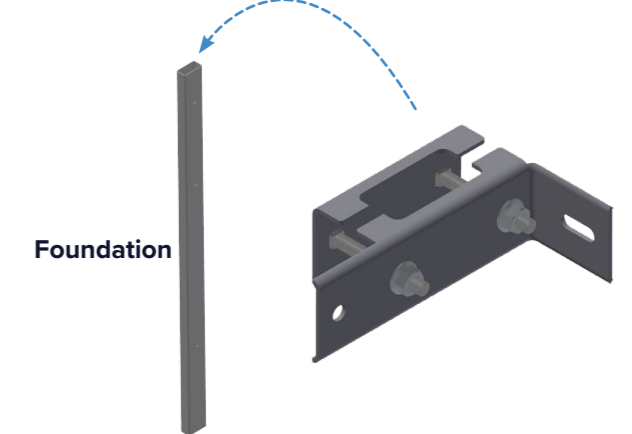

3. Loosely attach cotter

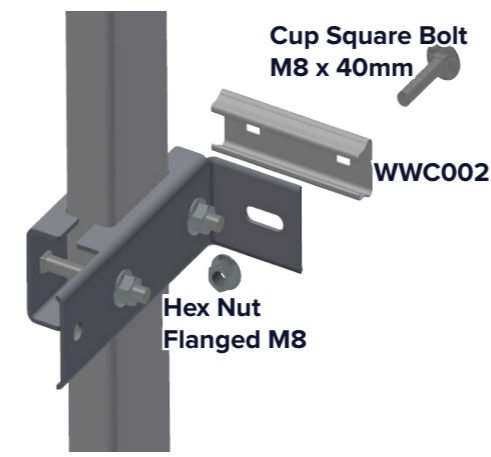

4. Slide base rails onto corner brackets

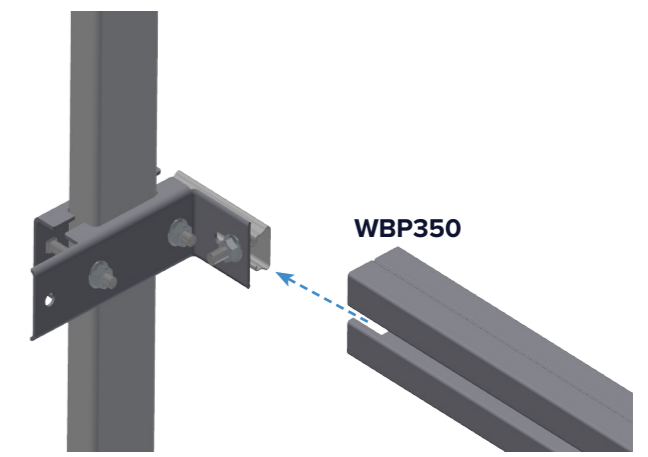

**Level and tighten base rails**

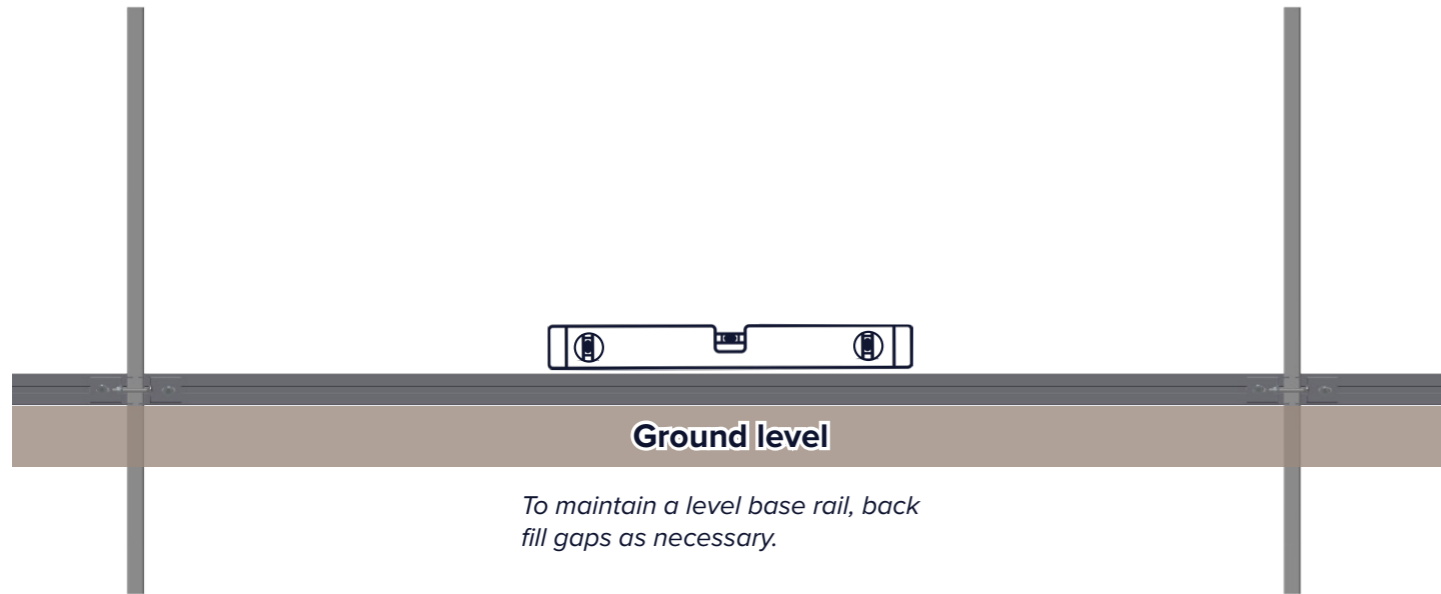

**i** Maintaining a level base rail is of particular importance if you have side ventilation.

**Hoop Assembly**

**Hoop parts**

Width	A	B	C
5 metre	CSS310	CSS301 x2	CSS311 x2
6 metre	CSS310	CSS303 x2	CSS311 x2
7 metre	CSS304	CSS305 x2	CSS311 x2
8 metre	CSS304	CSS306 x2	CSS311 x2
9 metre	CSS304	CSS307 x2	CSS311 x2

**For each hoop**

**1. Slot together hoop**

Slot together 5 piece hoop and fix each connection with nut and bolt.

**2. Slide hoop onto foundation tubes**

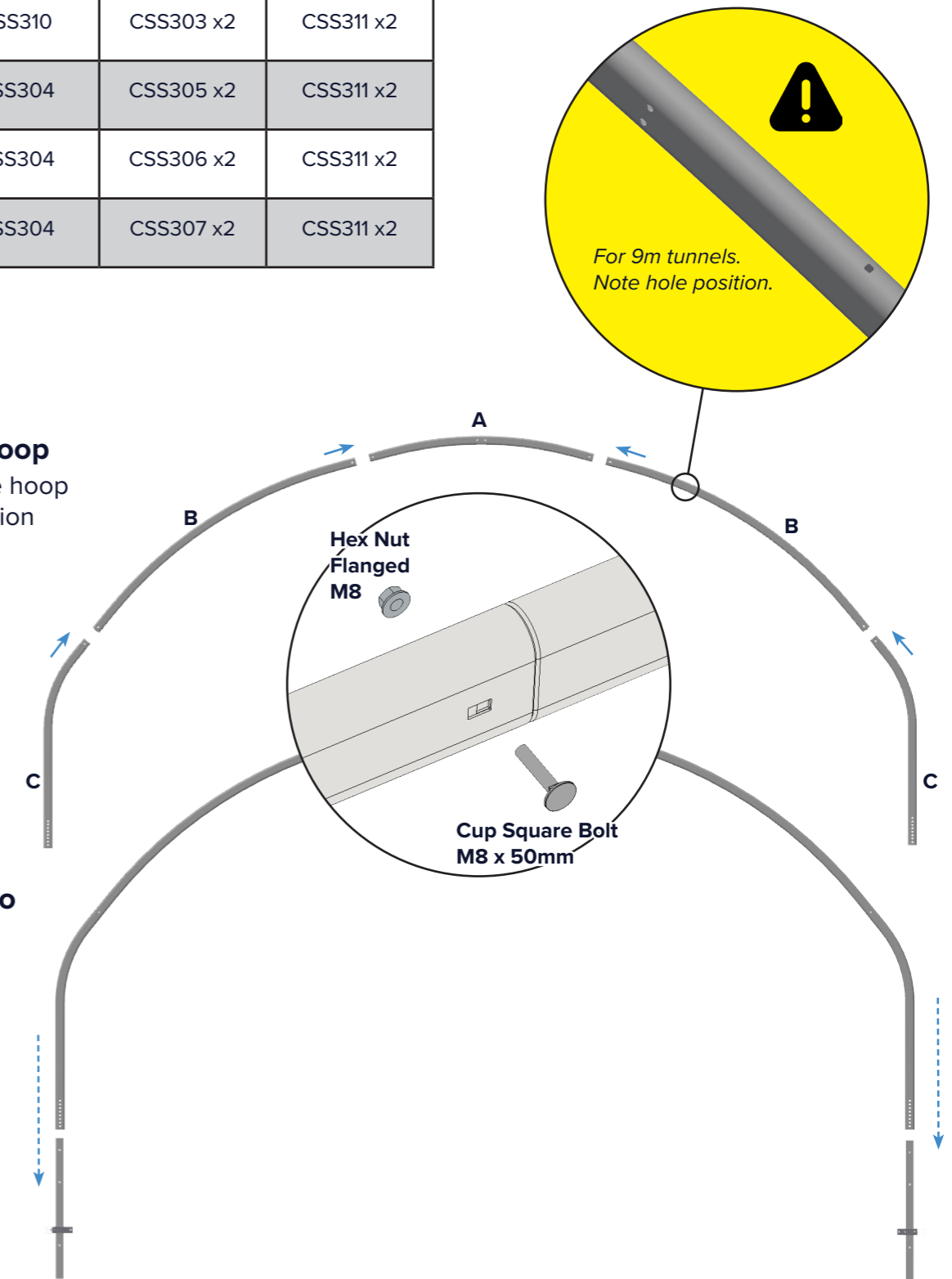

### Install Ridge Bars

#### 1. Attach first ridge bar

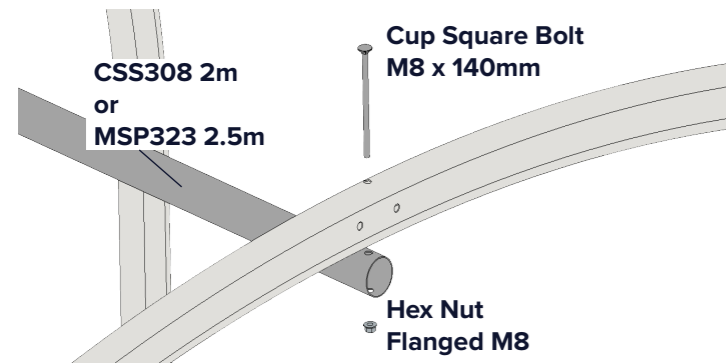

Starting at the front hoop, attach first ridge bar piece (CSS308) to hoop using nut and bolt.

#### 3. Fasten ridge tubes to hoops

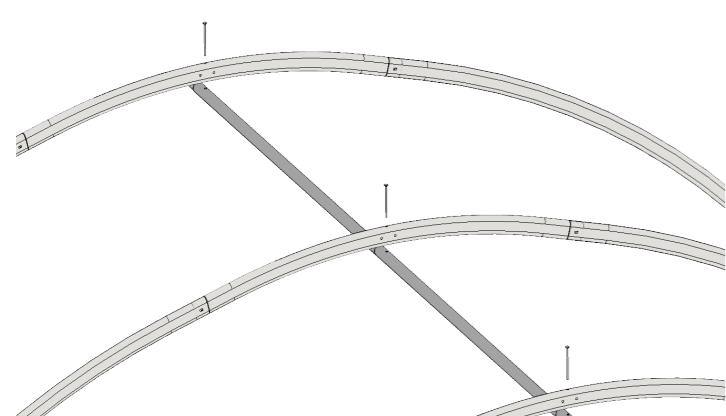

...and attach to hoop with nut and bolt. Continue for each hoop.

#### Raise Two Outer Hoops

Lift the two outer hoops by around 100mm and fix in place.

Leave all inner hoops at lowest level.

We'll use this for tensioning the cover in a later step.

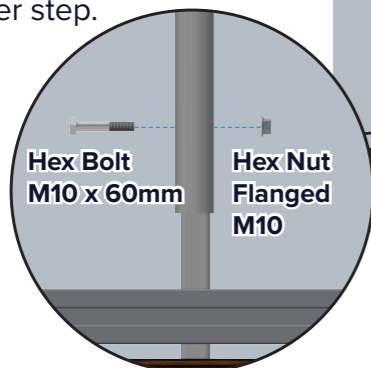

#### 2. Connect ridge tube lengths

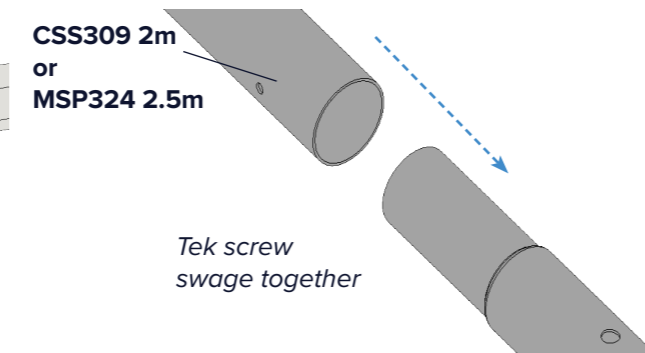

For each inner hoop, connect a length of ridge tube (CSS309)...

#### 4. Trim final ridge tube

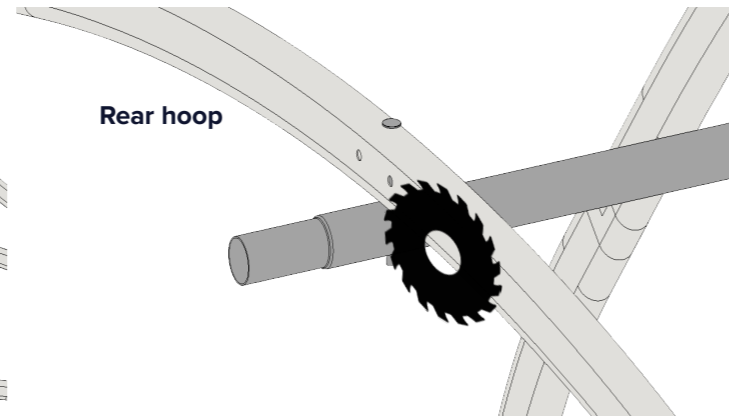

On the rear hoop, cut the protruding ridge bar flush with the outer face of the hoop. Insert plug RPP50.

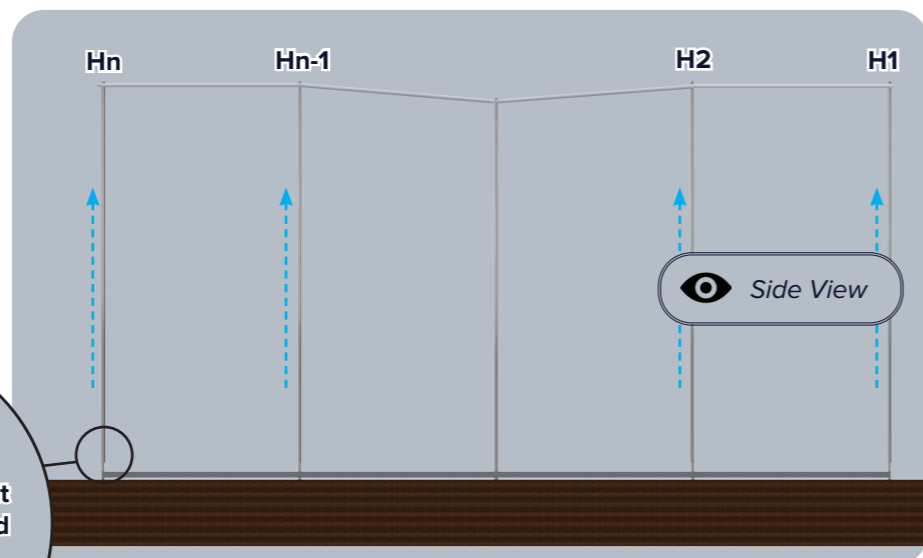

### Brace Bar Configuration

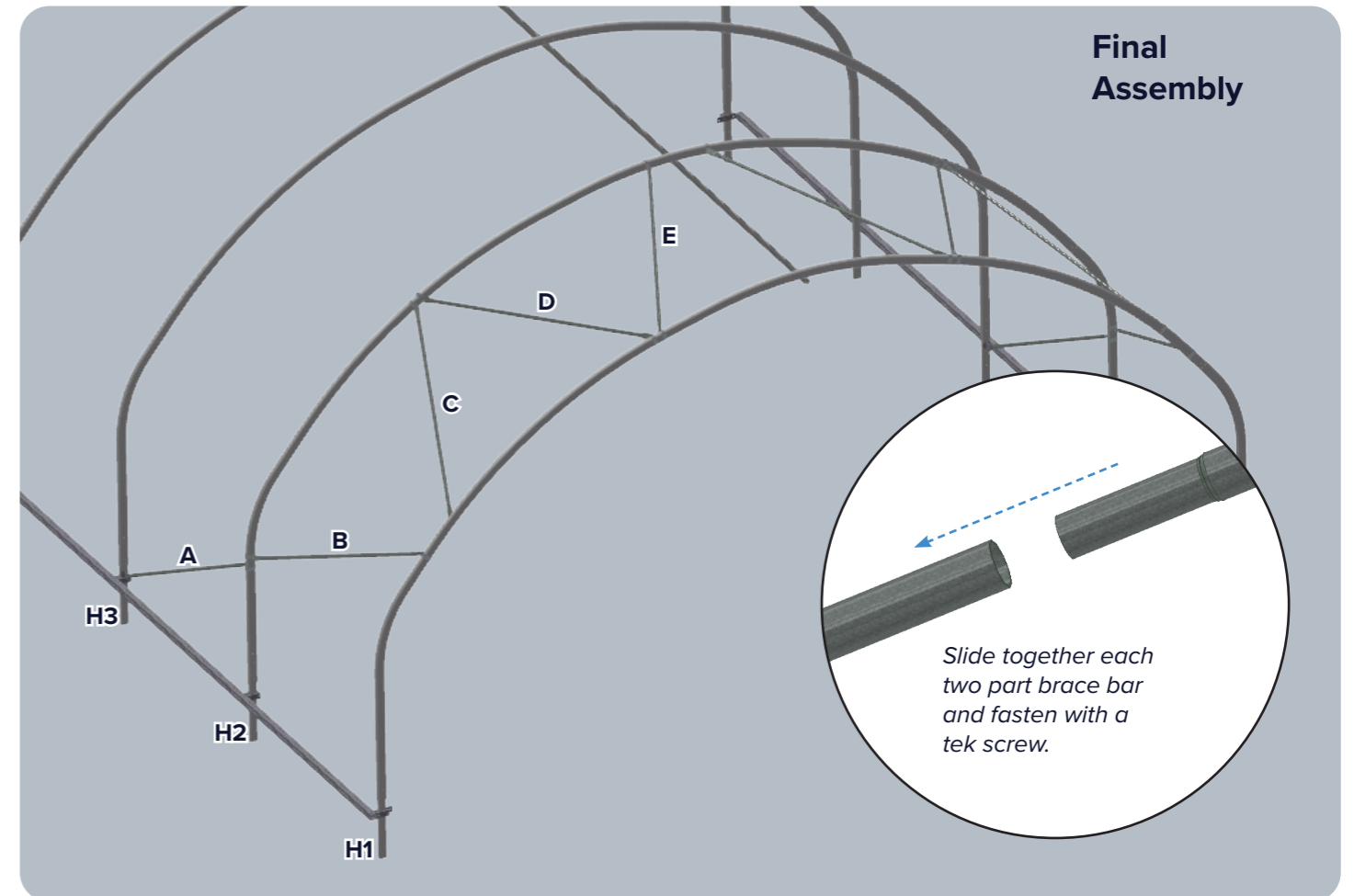

#### Hoop bracing parts

Each brace bar consists of two parts. Use the table below to identify your required brace bar parts.

#### Key to Part Codes

Example: BBP160 Ø32

{BB} {P/S} {160} {Ø32}  
 {Brace Bar} {Plain/Swaged} {Length in cm} {Diameter in mm}

Width	Hoop Spacing	A	B	C	D	E
5 metre	2500mm	BBP160 Ø32 BBS100 Ø32	BBP160 Ø32 BBS100 Ø32	BBP160 Ø32 BBS100 Ø32	BBP160 Ø32 BBS100 Ø32	BBP160 Ø32 BBS100 Ø32
6 metre	2500mm	BBP160 Ø32 BBS102 Ø32	BBP160 Ø32 BBS102 Ø32	BBP160 Ø32 BBS102 Ø32	BBP160 Ø32 BBS102 Ø32	BBP160 Ø32 BBS102 Ø32
7 metre	2000mm	BBP160 Ø32 BBS060 Ø32	BBP160 Ø32 BBS060 Ø32	BBP160 Ø32 BBS060 Ø32	BBP160 Ø32 BBS060 Ø32	BBP160 Ø32 BBS060 Ø32
8 metre	2000mm	BBP183 Ø50 BBS040 Ø50	BBP183 Ø50 BBS040 Ø50	BBP160 Ø32 BBS071 Ø32	BBP160 Ø32 BBS071 Ø32	BBP160 Ø32 BBS071 Ø32
9 metre	2000mm	BBP183 Ø50 BBS040 Ø50	BBP183 Ø50 BBS040 Ø50	BBP183 Ø50 BBS040 Ø50	BBP160 Ø32 BBS094 Ø32	BBP160 Ø32 BBS094 Ø32

# Fitting Brace Bars

## 1. Place keyhole brackets

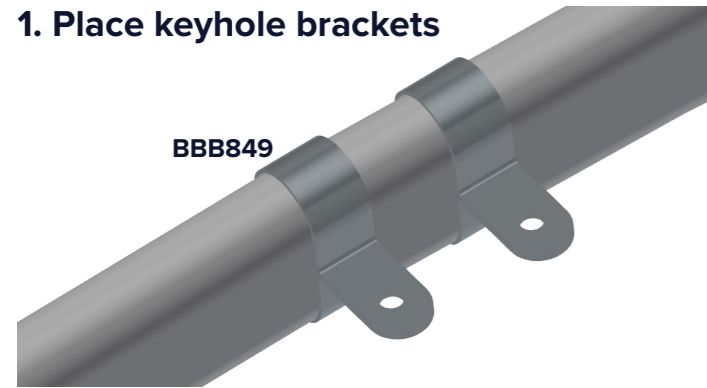

Place keyhole brackets on hoops. Splay the bracket to slide over the hoop.

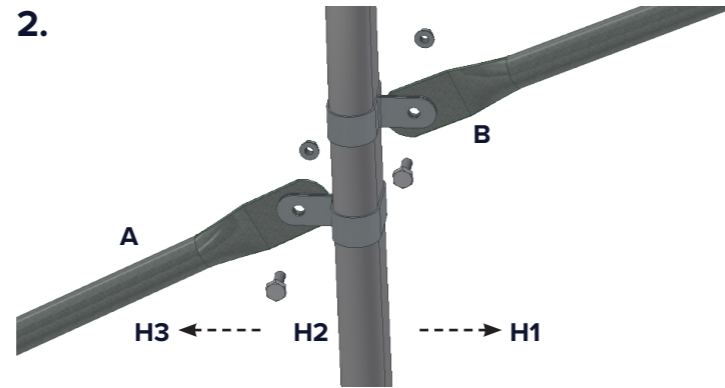

Note bracket configuration for brace bar **A** & **B** on hoop **H2**.

## 3. Attach brace bars

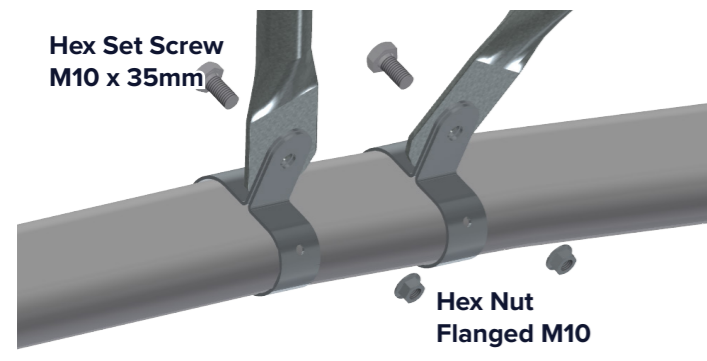

Attach brace bars to key hole clamps with nut and bolt.

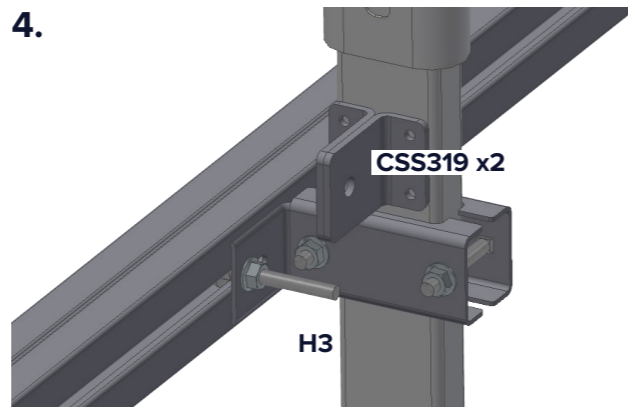

Note hoop **H3**. Attach bracket with tek screw and bolt brace bar **A** to bracket.

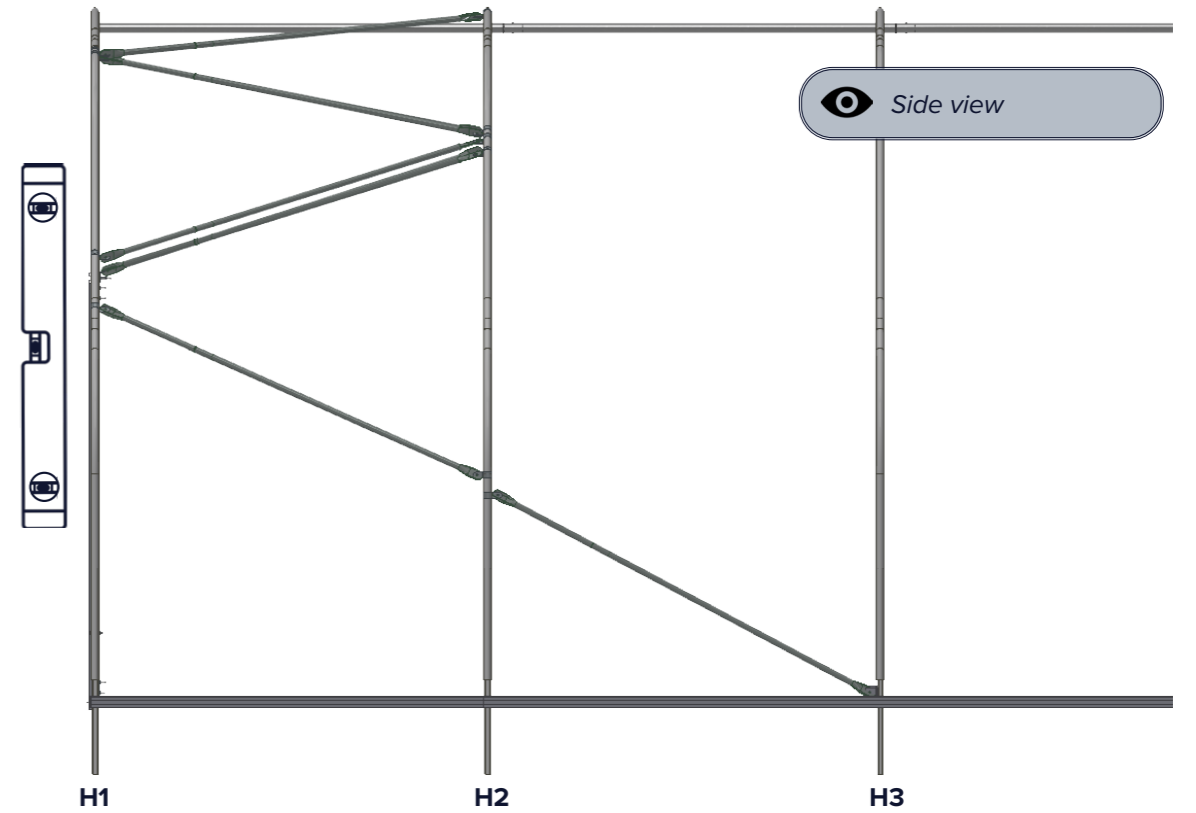
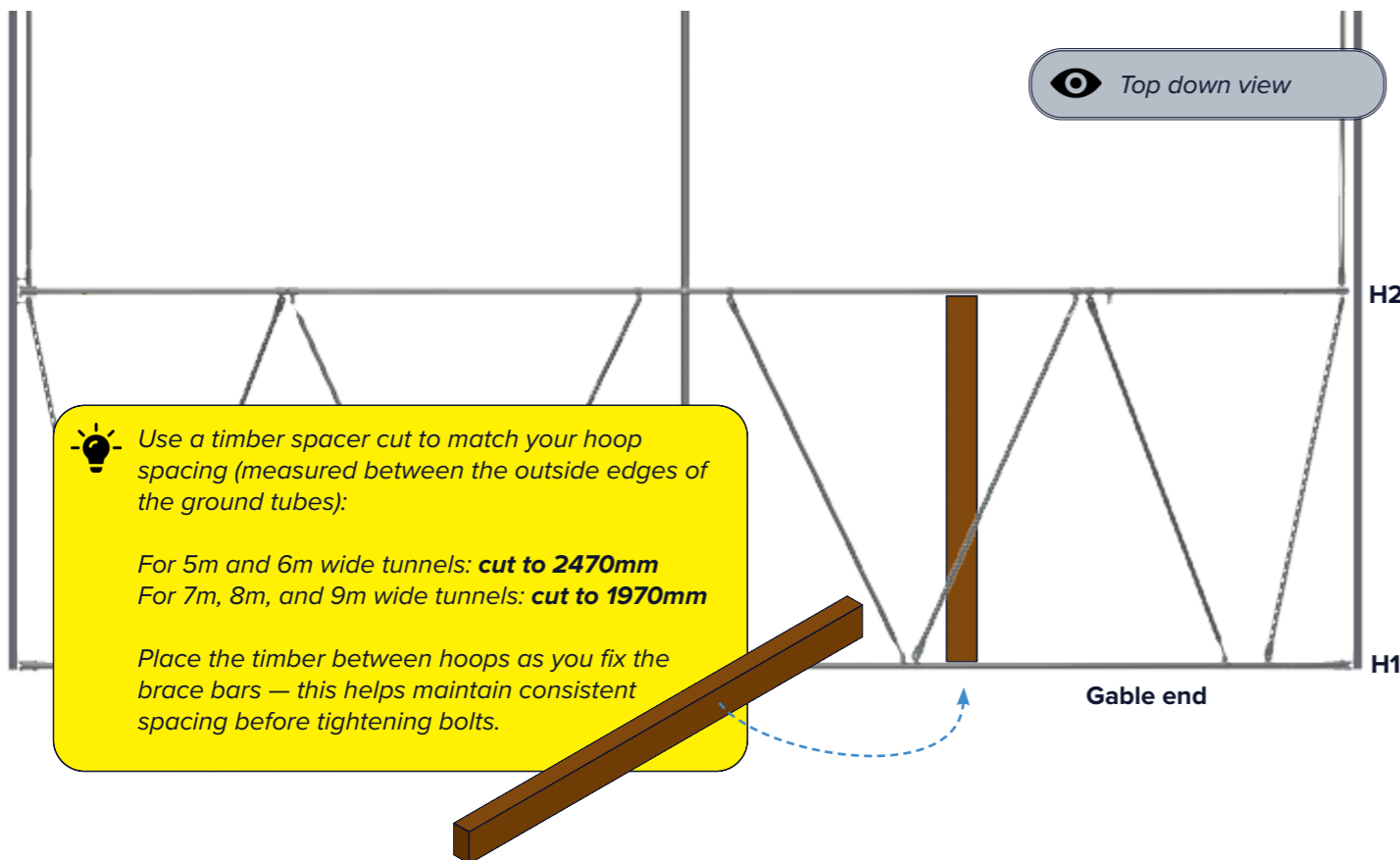

Ensure all hoops are vertical before fully tightening up. Fix brackets to hoops with tek screws.

Refer to image below for final configuration. Mirror configuration to complete the front end bracing as pictured below. Then repeat at the rear end of the tunnel.

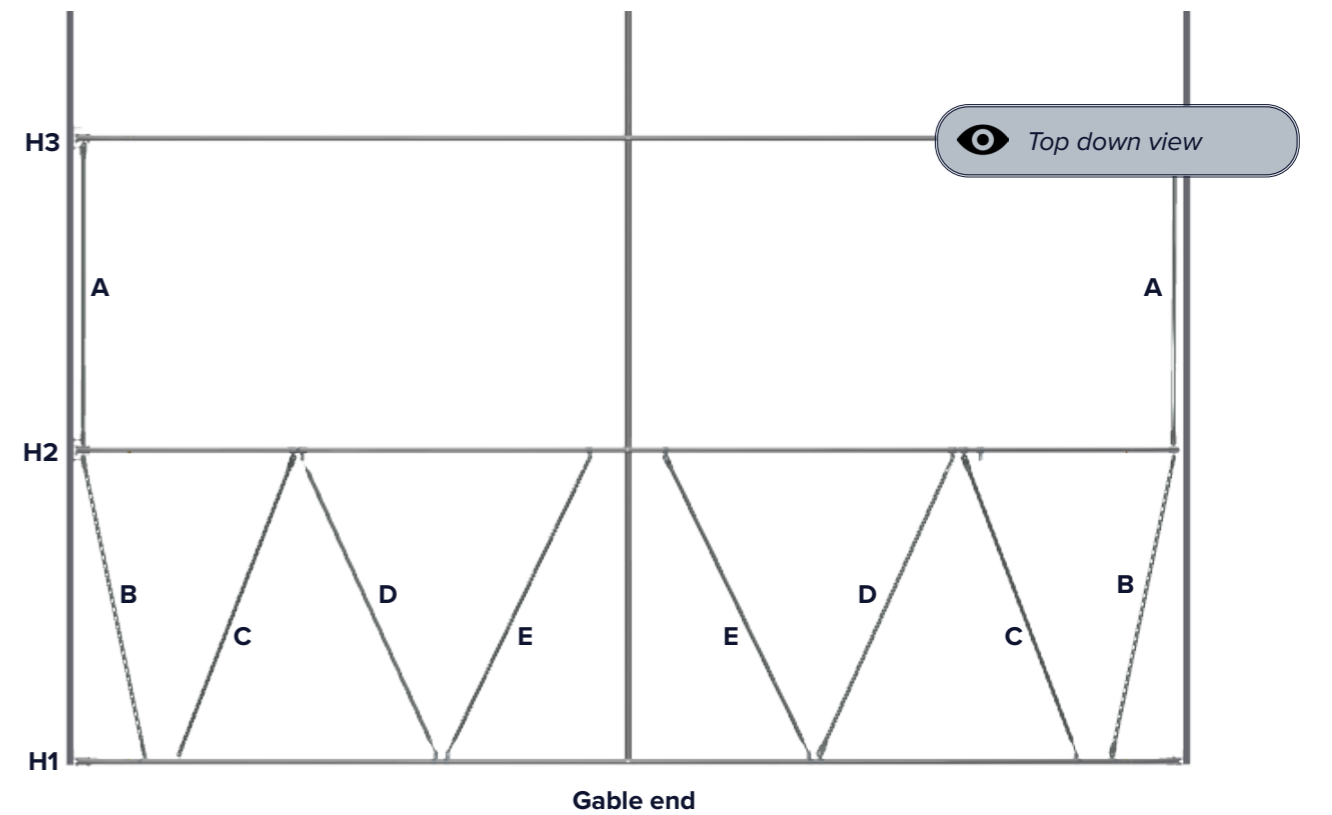

## Gable End Frame Configuration

Review the diagrams and tables for the correct gable end configuration.

### 5m wide configuration

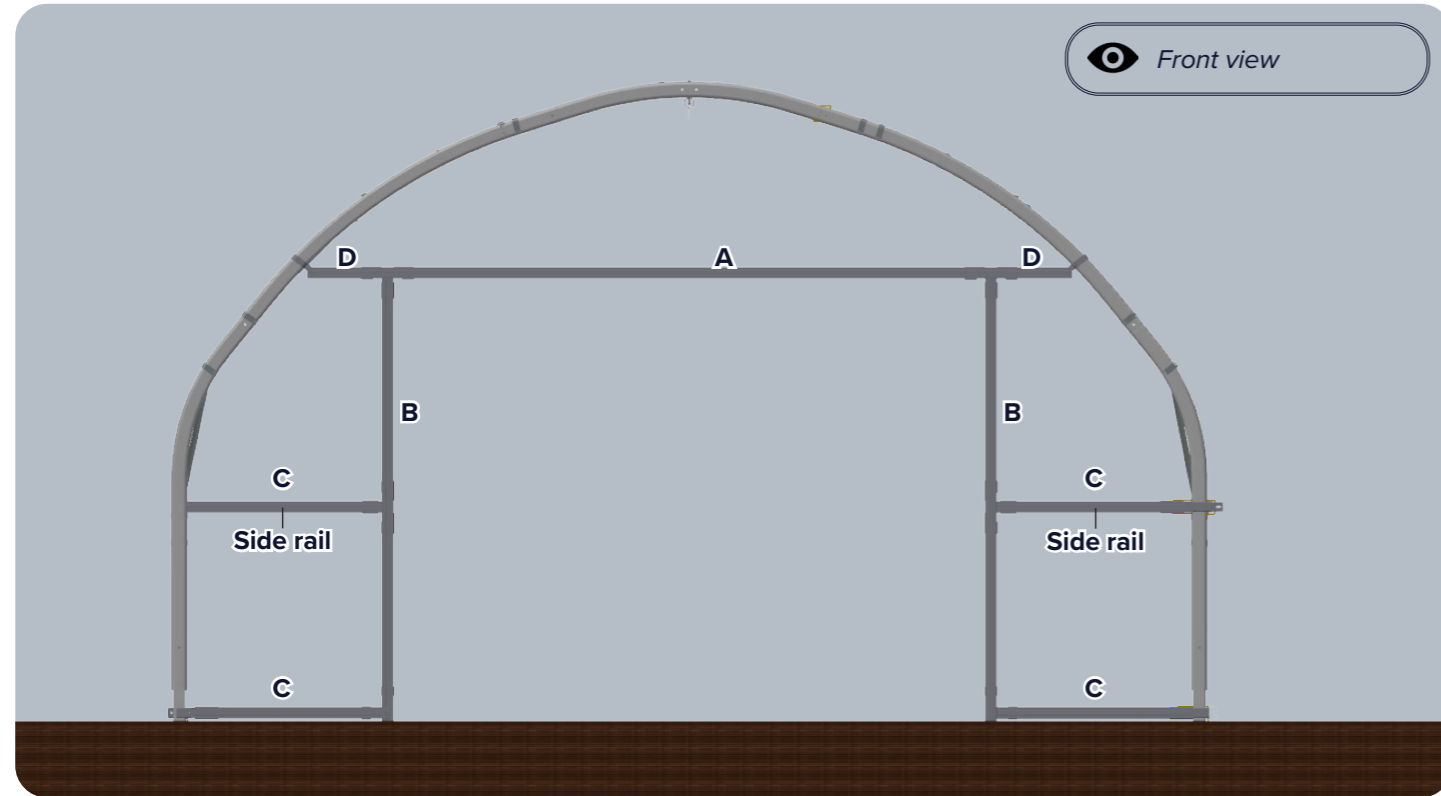

**!** Side Rail only required if polytunnel includes side rails.

#### Gable End Parts

Box profile lengths are oversized and require cutting to size.

Width	A	B	C	D	Fittings
5 metre	WBP290 x1	WBP290 x2	WBP210 x1	WBP080 x2	CSS200

### 6m & 7m wide configuration

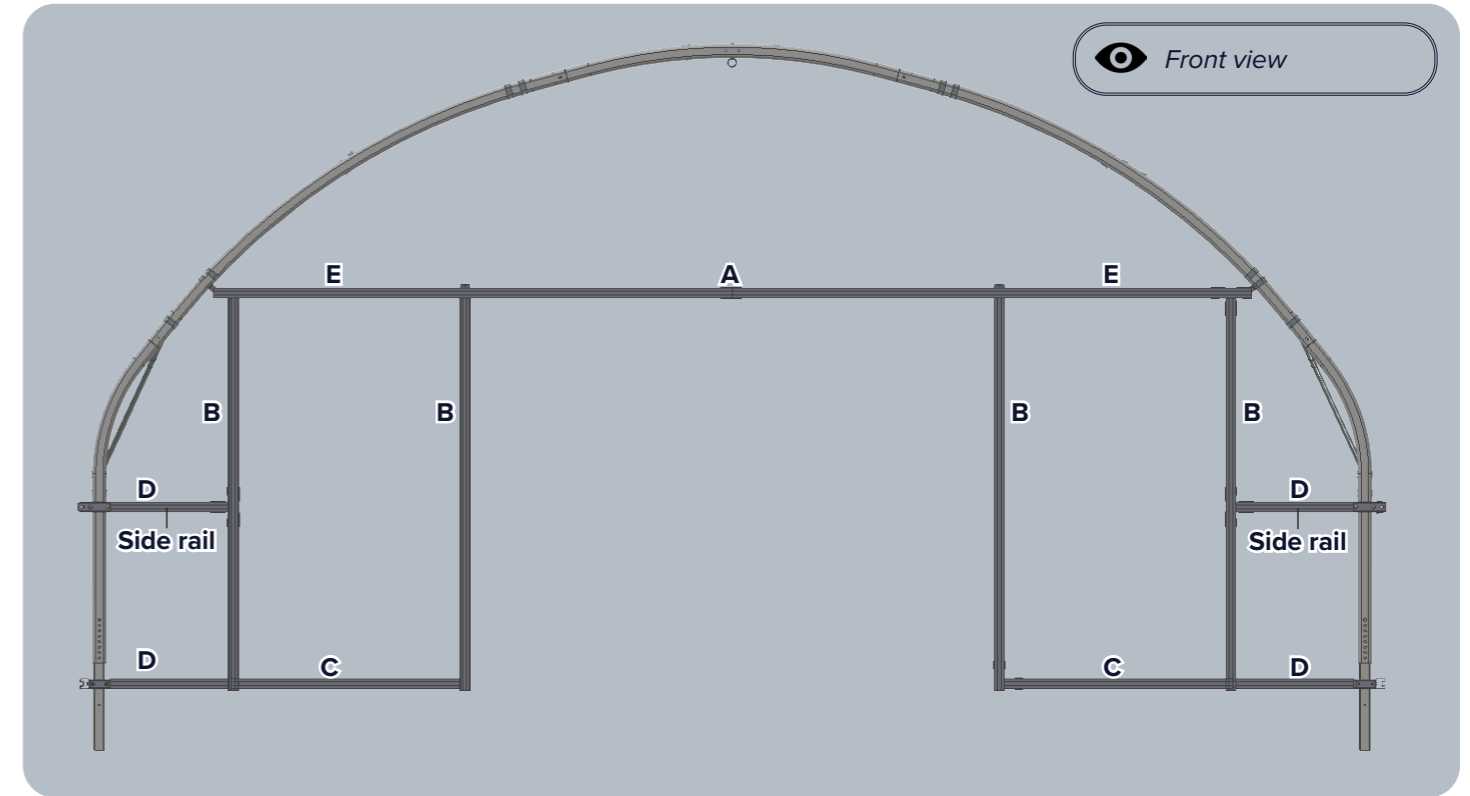

**!** Side Rail only required if polytunnel includes side rails.

#### Gable End Parts

Box profile lengths are oversized and require cutting to size.

Width	A	B	C	D	E	Fittings
6 metre	WBP290 x1	WBP290 x4	WBP080 x2	WBP080 x4	WBP170 x2	CSS201
7 metre	WBP290 x1	WBP290 x4	WBP170 x2	WBP080 x4	WBP170 x2	CSS201

For "8m & 9m wide configuration" see page 24

**8m & 9m wide configuration**

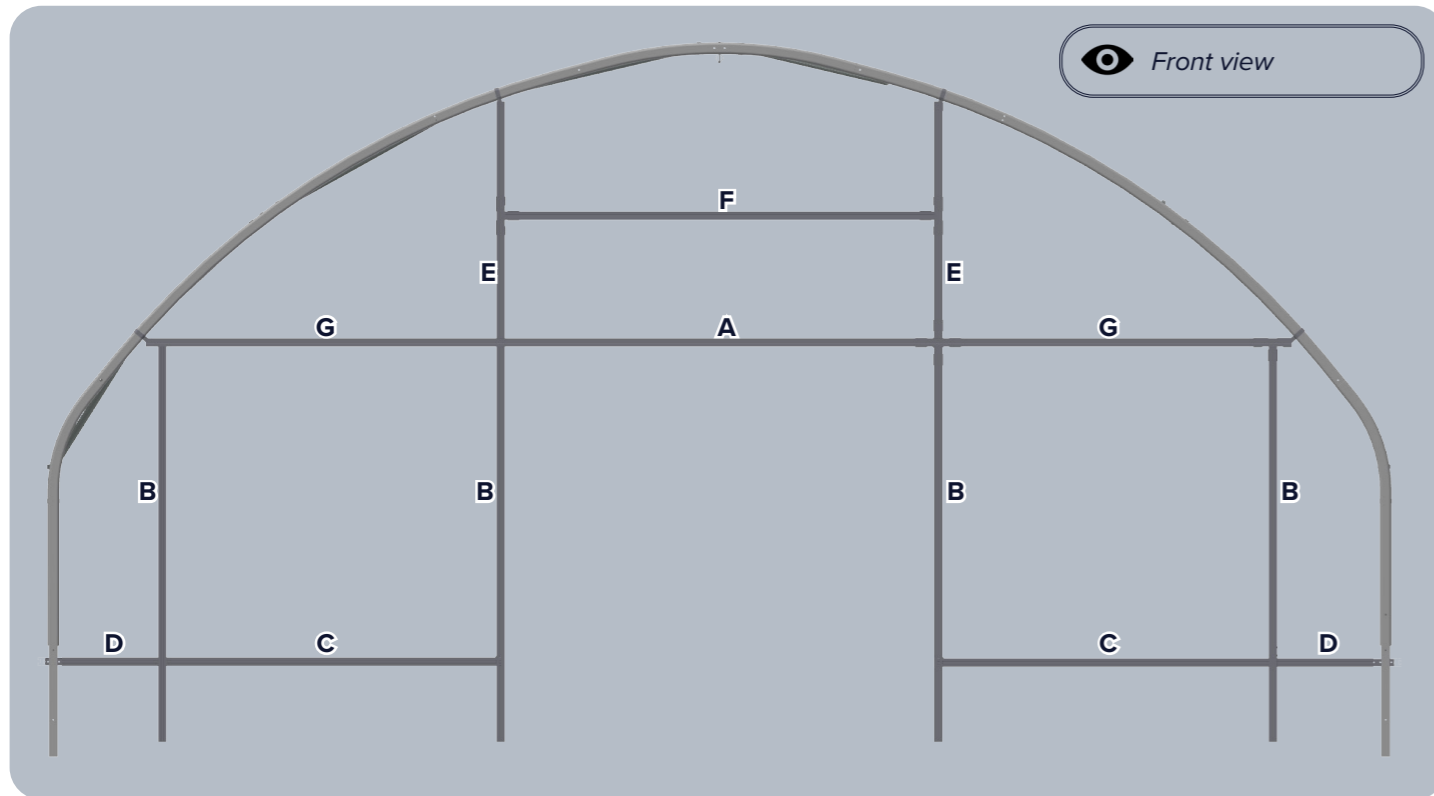

**Gable End Parts**

Box profile lengths are oversized and require cutting to size.

**!** *Side Rail* only required if polytunnel includes side rails.

Width	A	B	C	D
8 metre	WBP290 x1	WBP290 x4	WBP210 x2	WBP080 x4
9 metre	WBP290 x1	WBP290 x4	WBP250 x2	WBP080 x4

Width	E	F	G	Fittings
8 metre	WBP210 x2	WBP290 x1	WBP210 x2	CSS201
9 metre	WBP210 x2	WBP290 x1	WBP290 x2	CSS201

# Fitting Gable End Frame

**i** Finger tighten only at this stage.

## 1. Assemble lintel. Fit to centre of 2.9m length.

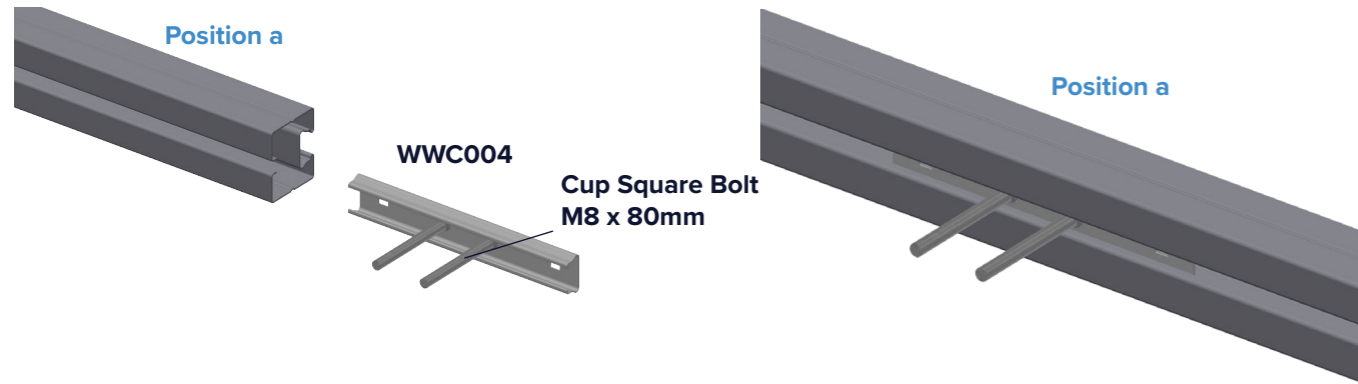

If above door louvre supplied:

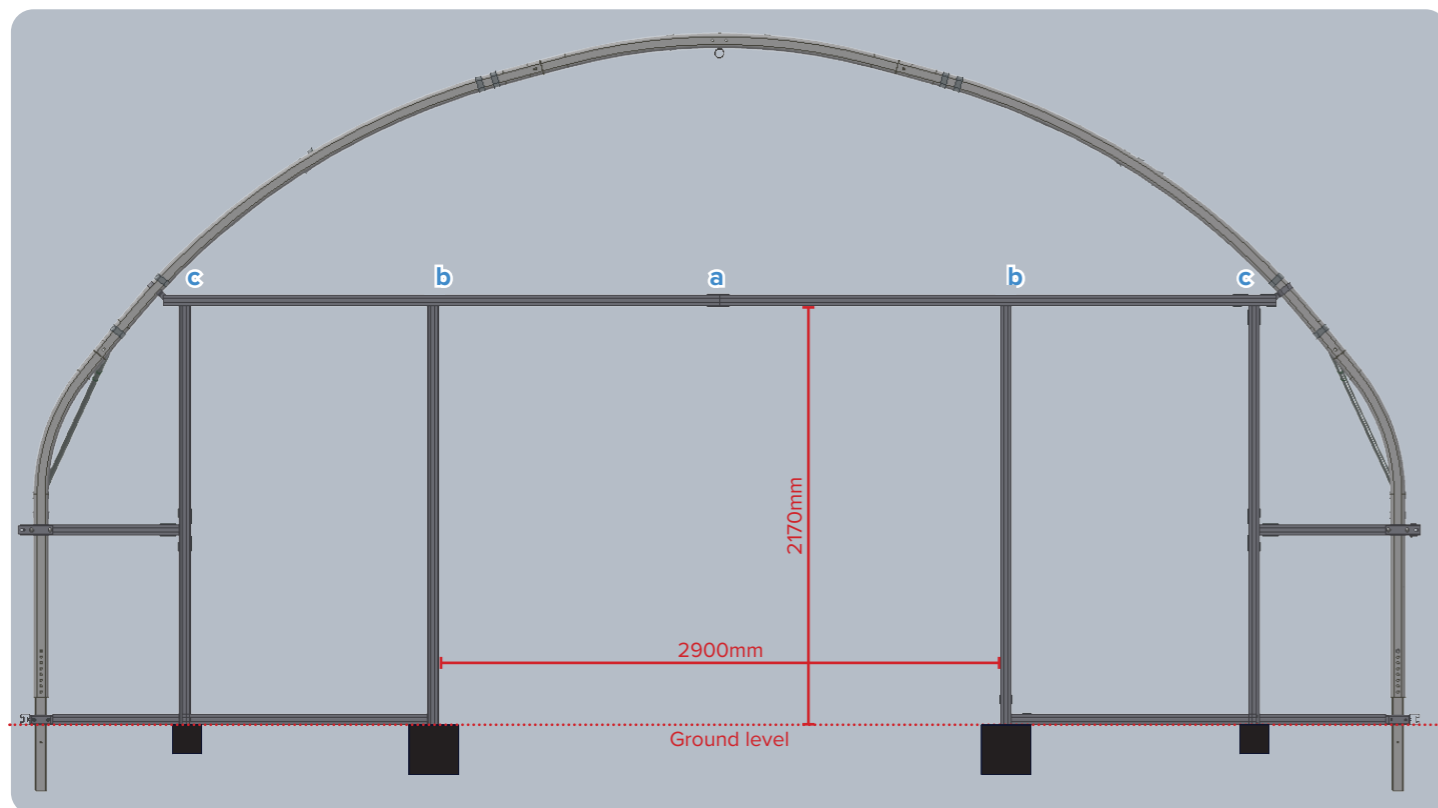
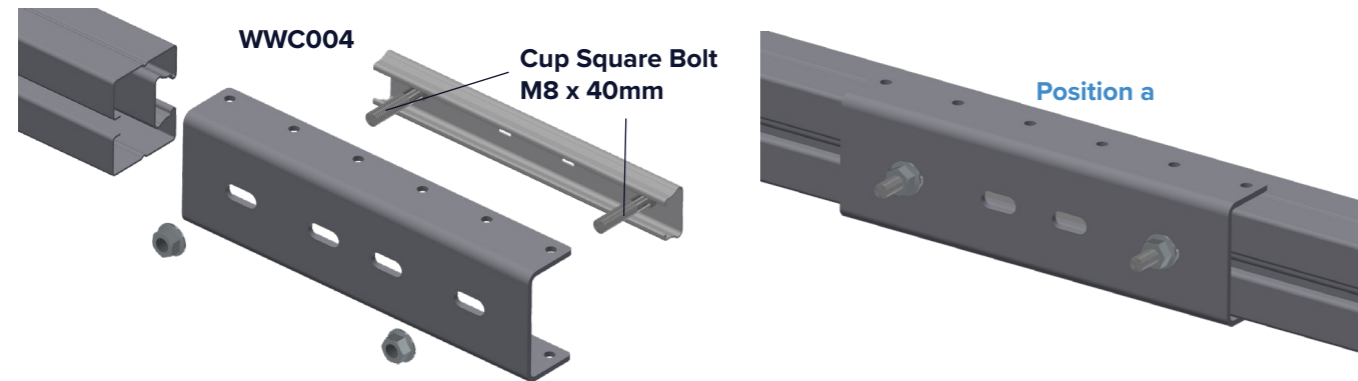

## 2. Join lintel using door post brackets at position b

For 5m, 6m & 7m polytunnels

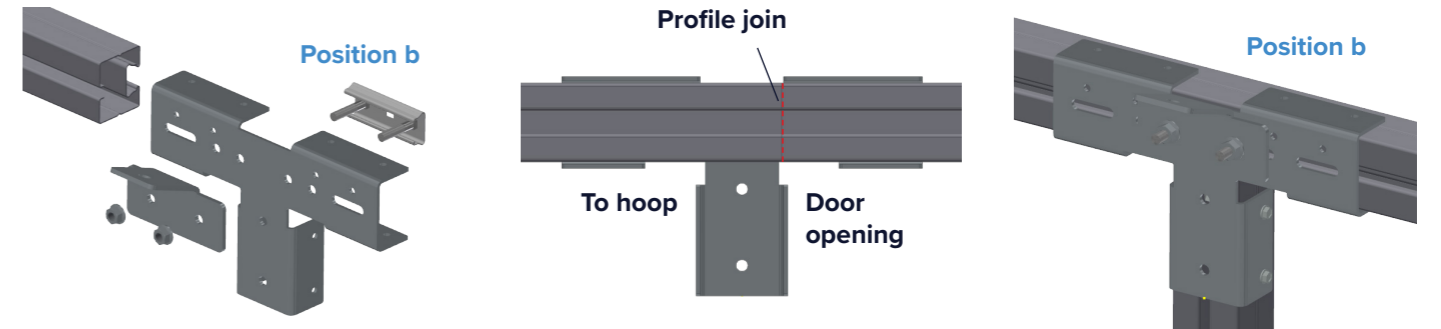

For 8m & 9m polytunnels

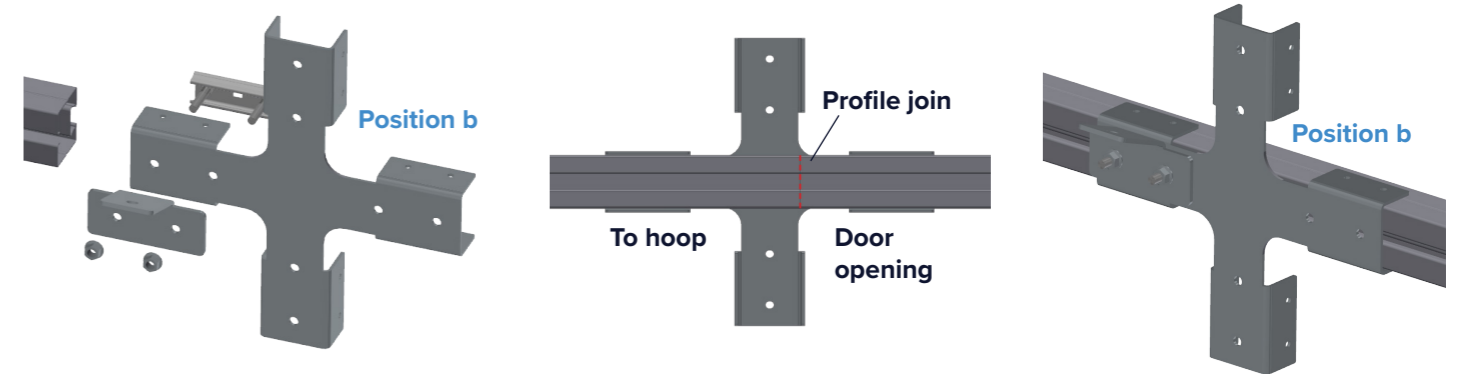

## 3. Attach lintel to hoop at position c

For 5m polytunnels

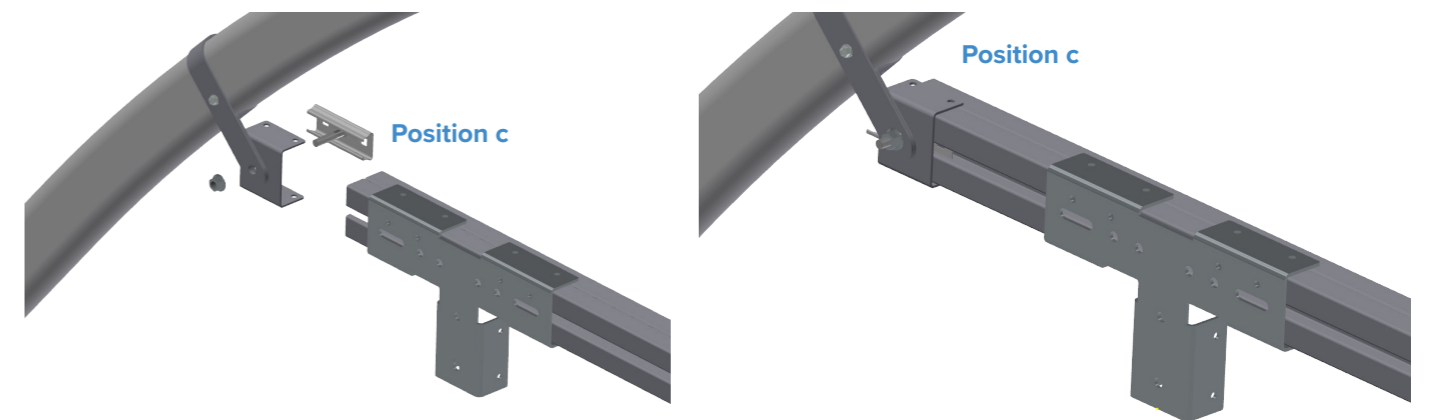

For 6m, 7m, 8m & 9m polytunnels

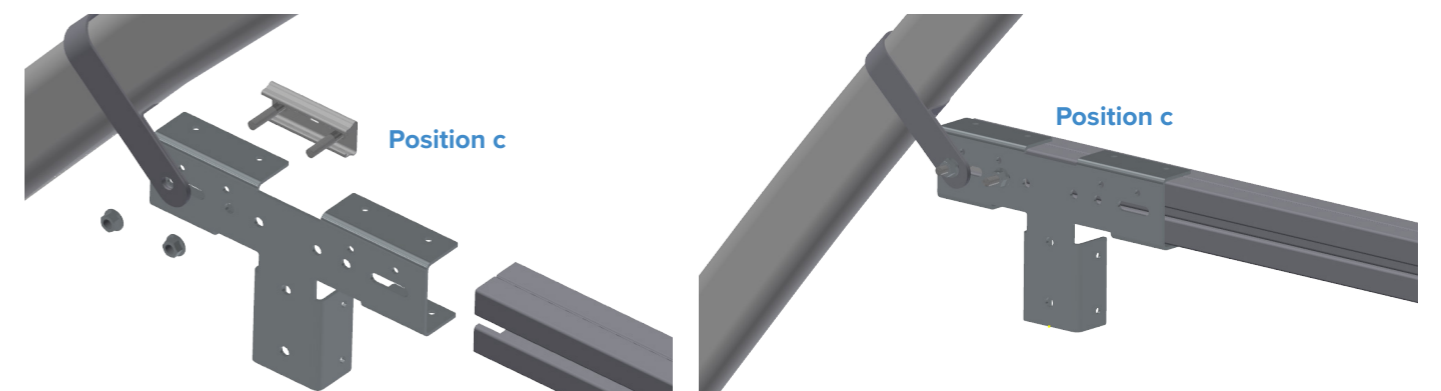

### 4. Install lintel centre support

**!** Skip if installing louvres or 8m, 9m tunnel.

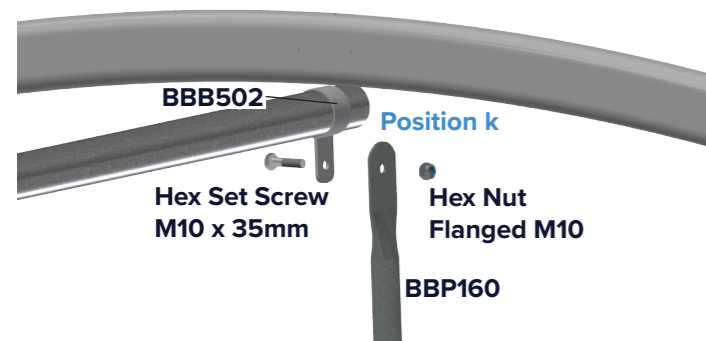
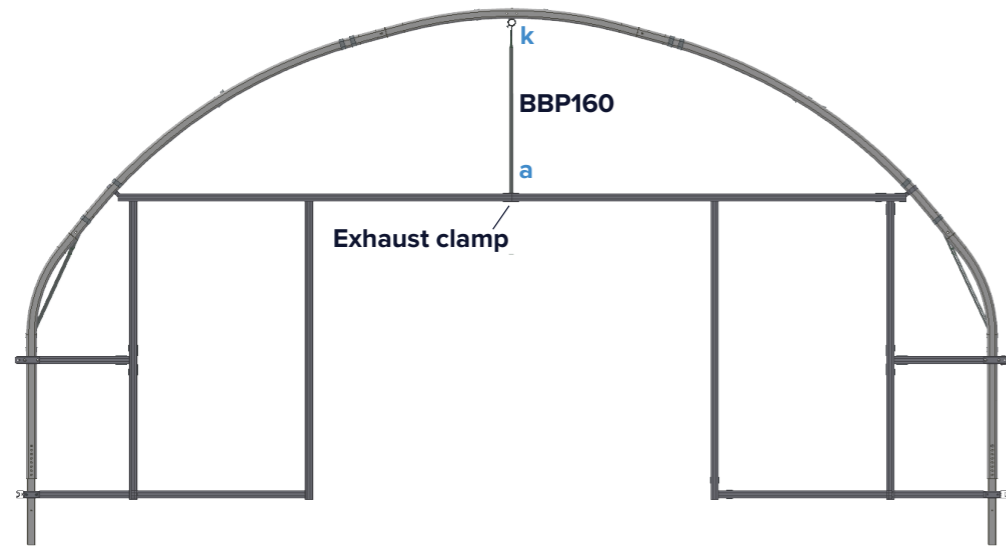

Attach centre support to ridge bar with bracket.

### Trim centre support

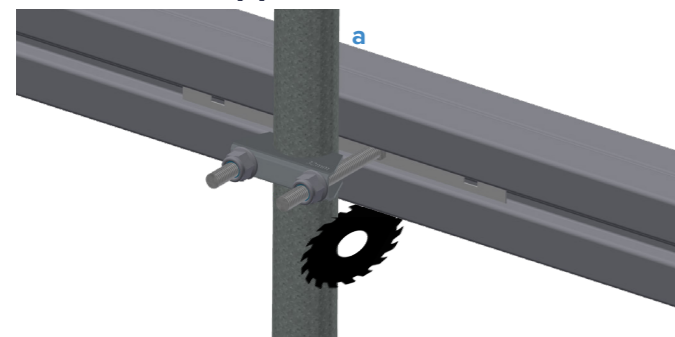

Then cut centre support flush with the underside of the lintel.

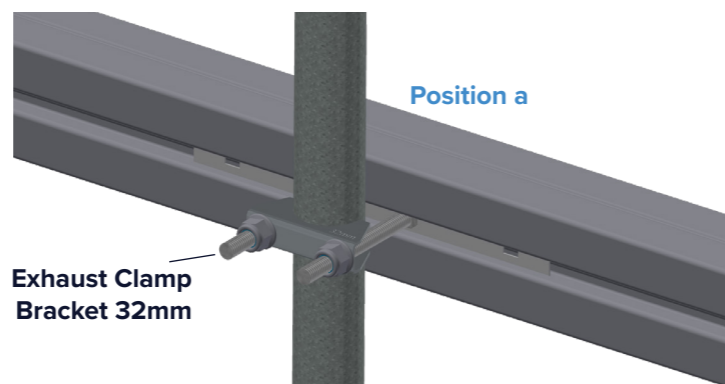

Attach centre support to lintel with exhaust clamp.

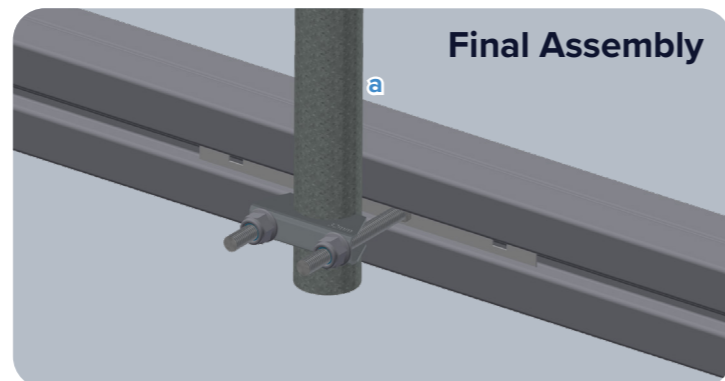

### 5. Fit door posts

Position b & c

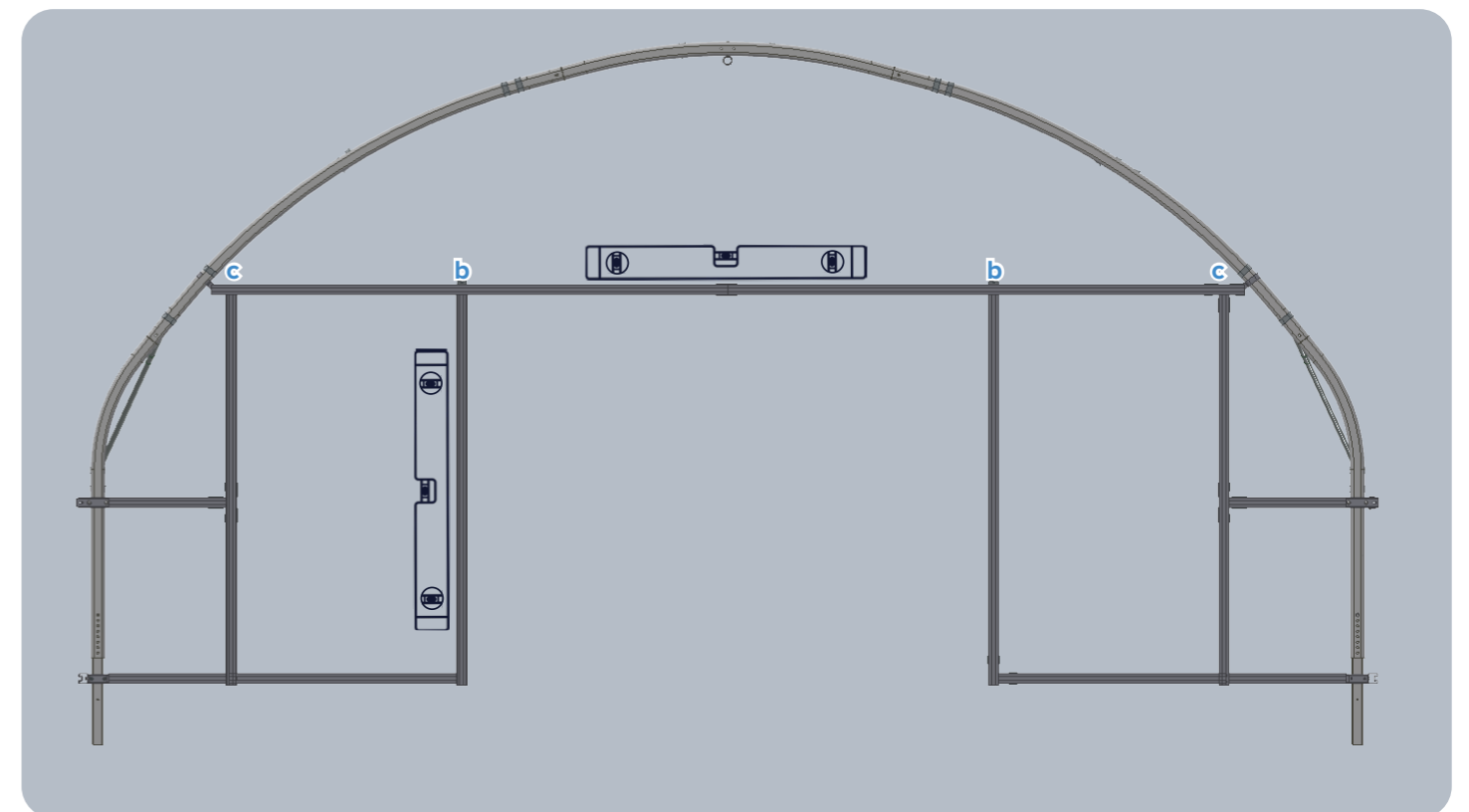
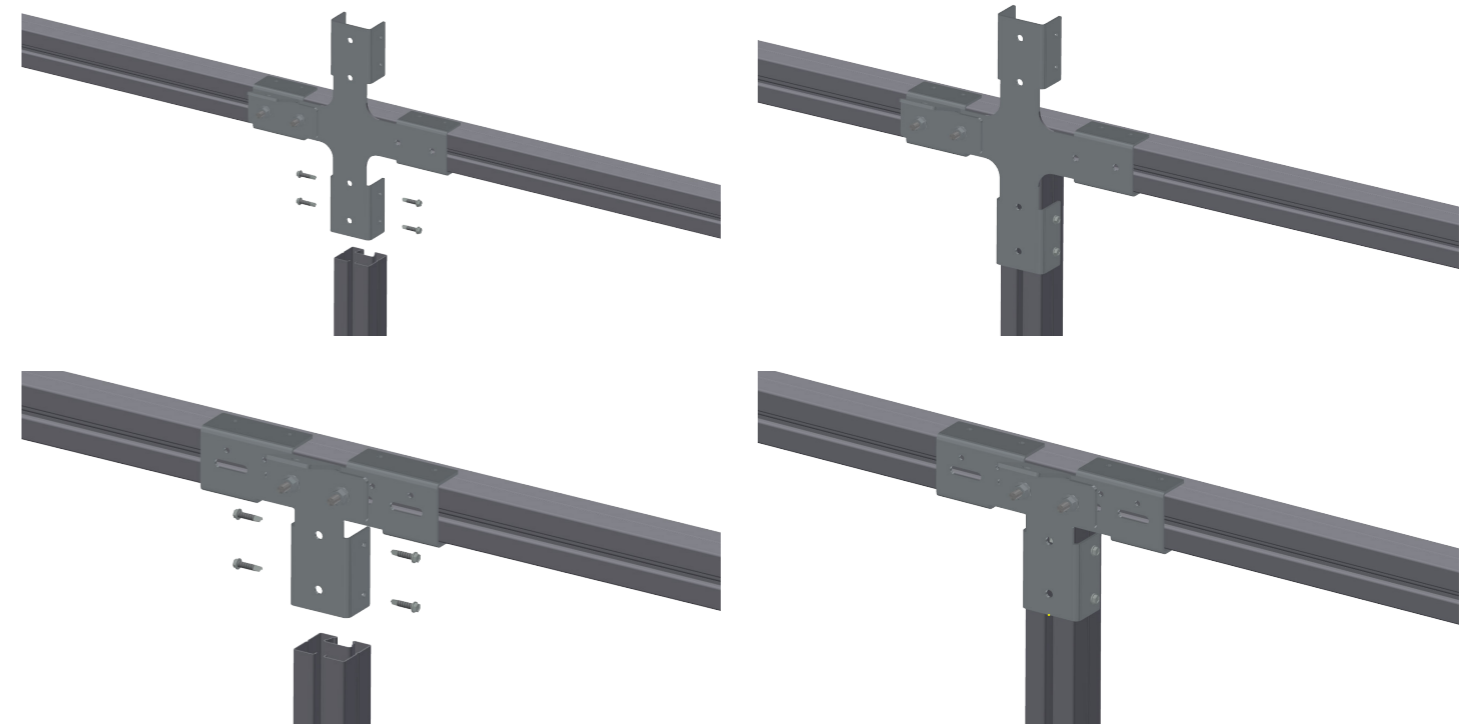

**!** Check levels on all bars before tek screwing.

### 6. Fit base rail

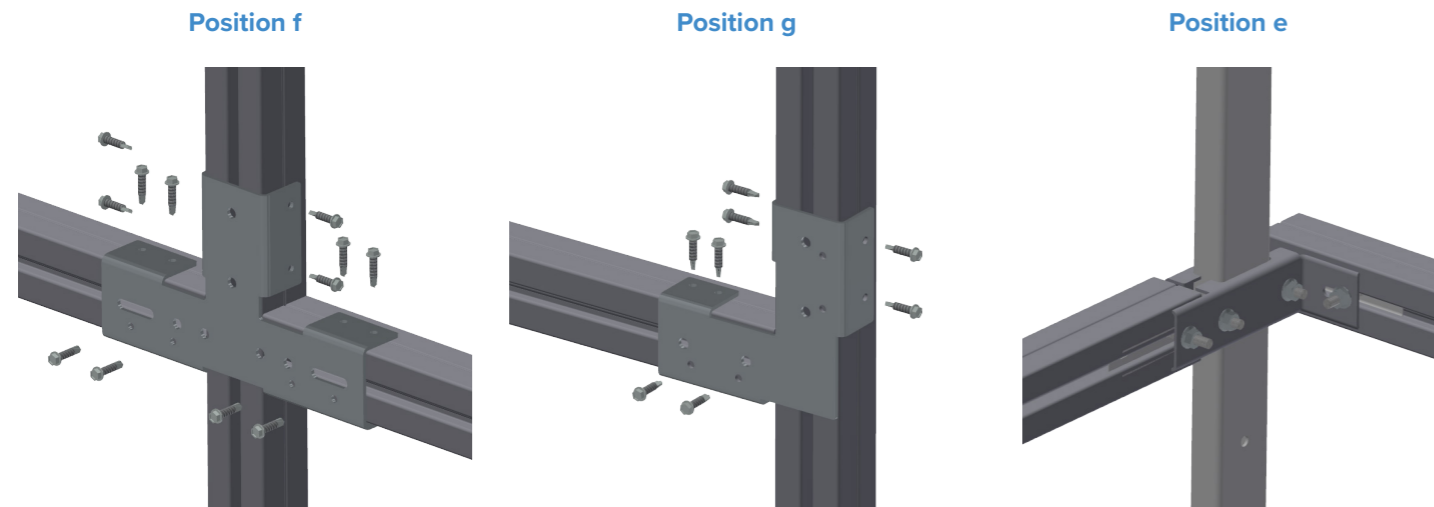
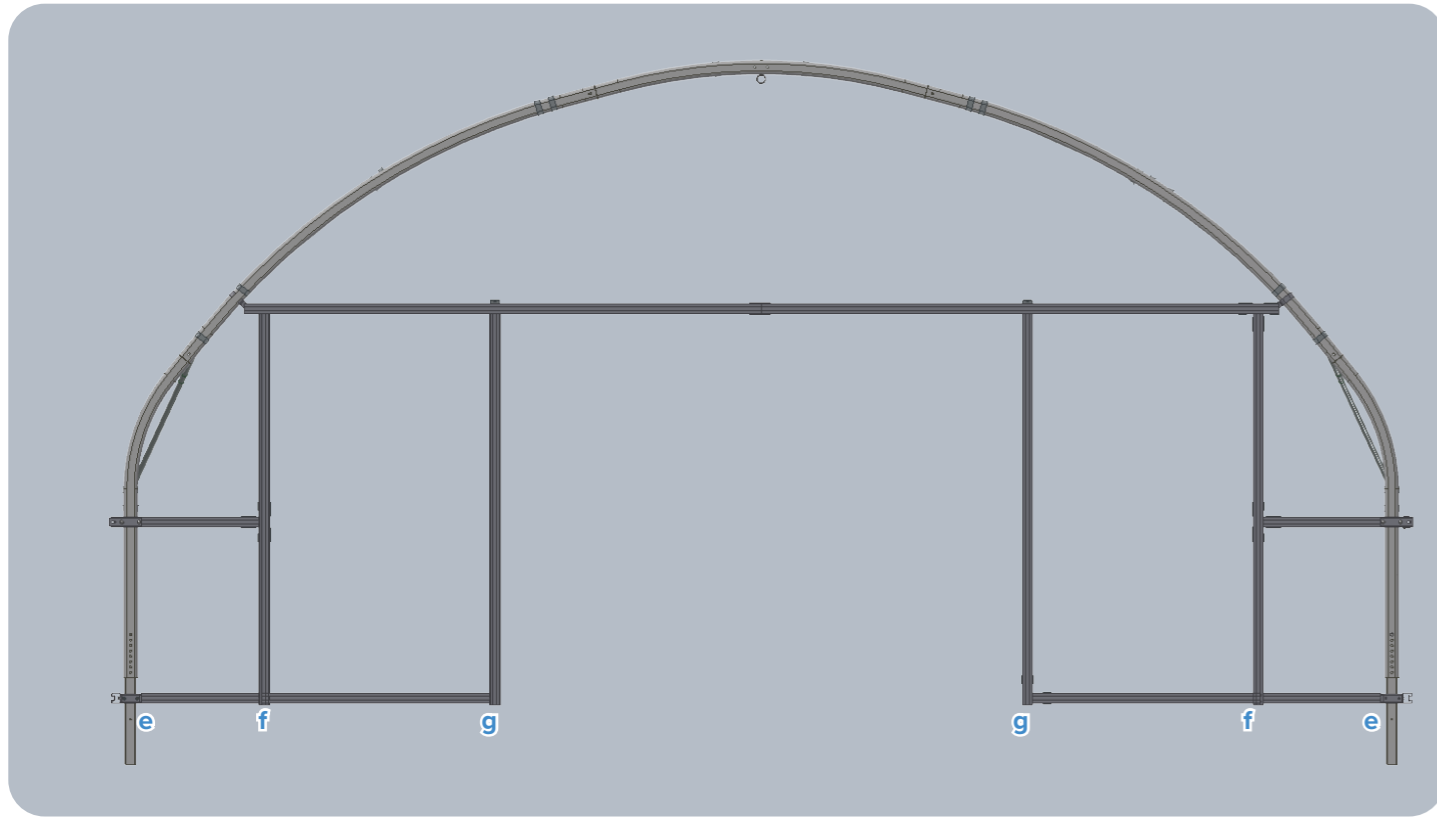

### 7. Attach gable end side rail (if required)

**⚠ Skip these steps if NOT installing wiggle wire over hoop.**

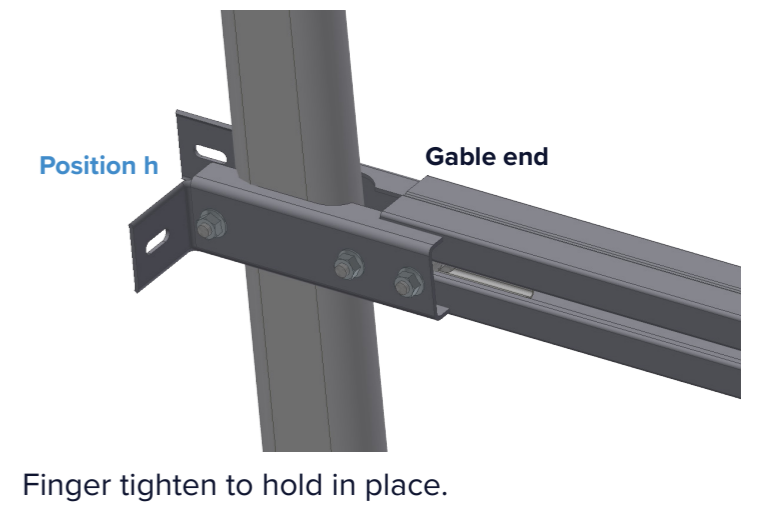
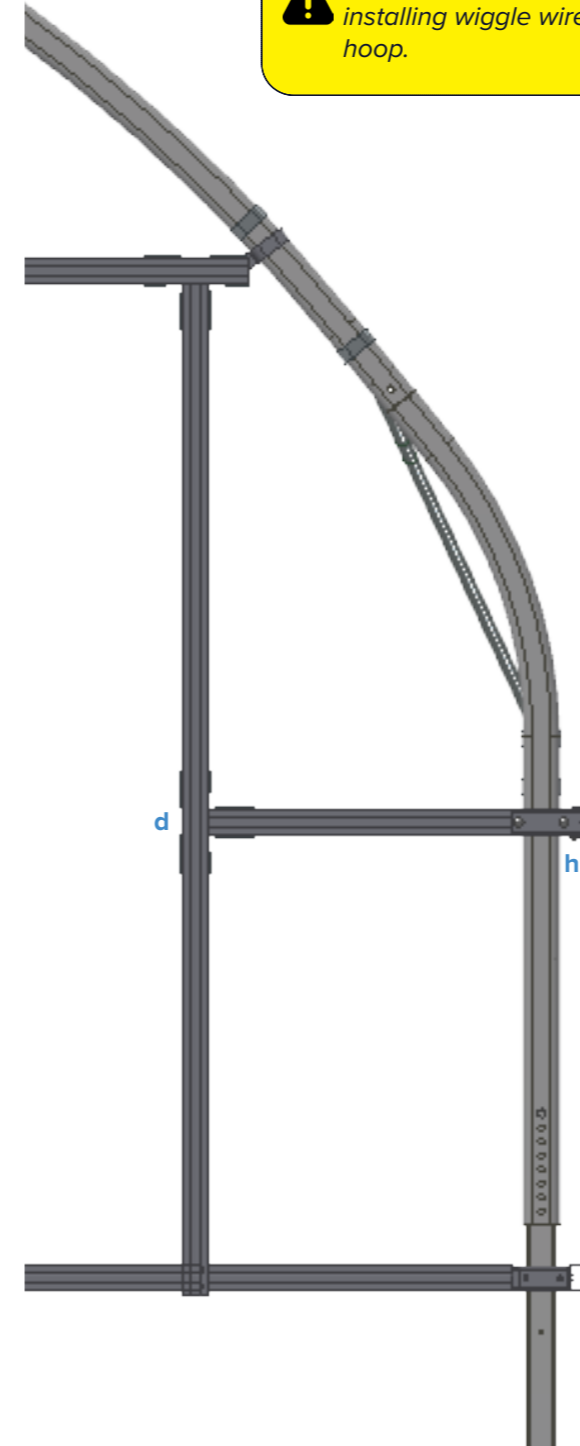

#### Attach to upright

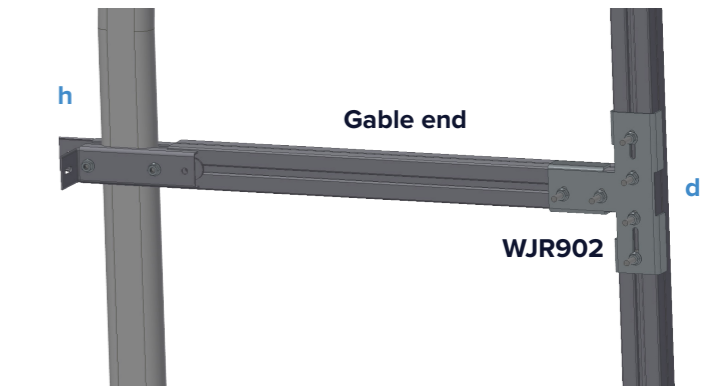

Attach gable end side rail to upright at position **d** using a T bracket. You should have two loose cotters in the upright from an earlier step.

### 8. Install H frame

Only applies to 8m, & 9m wide tunnels.

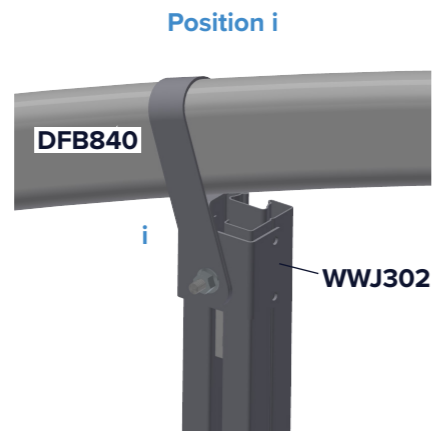
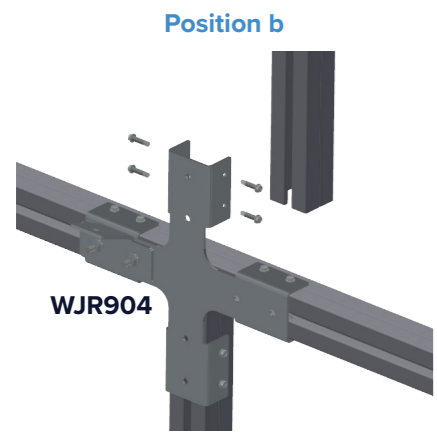
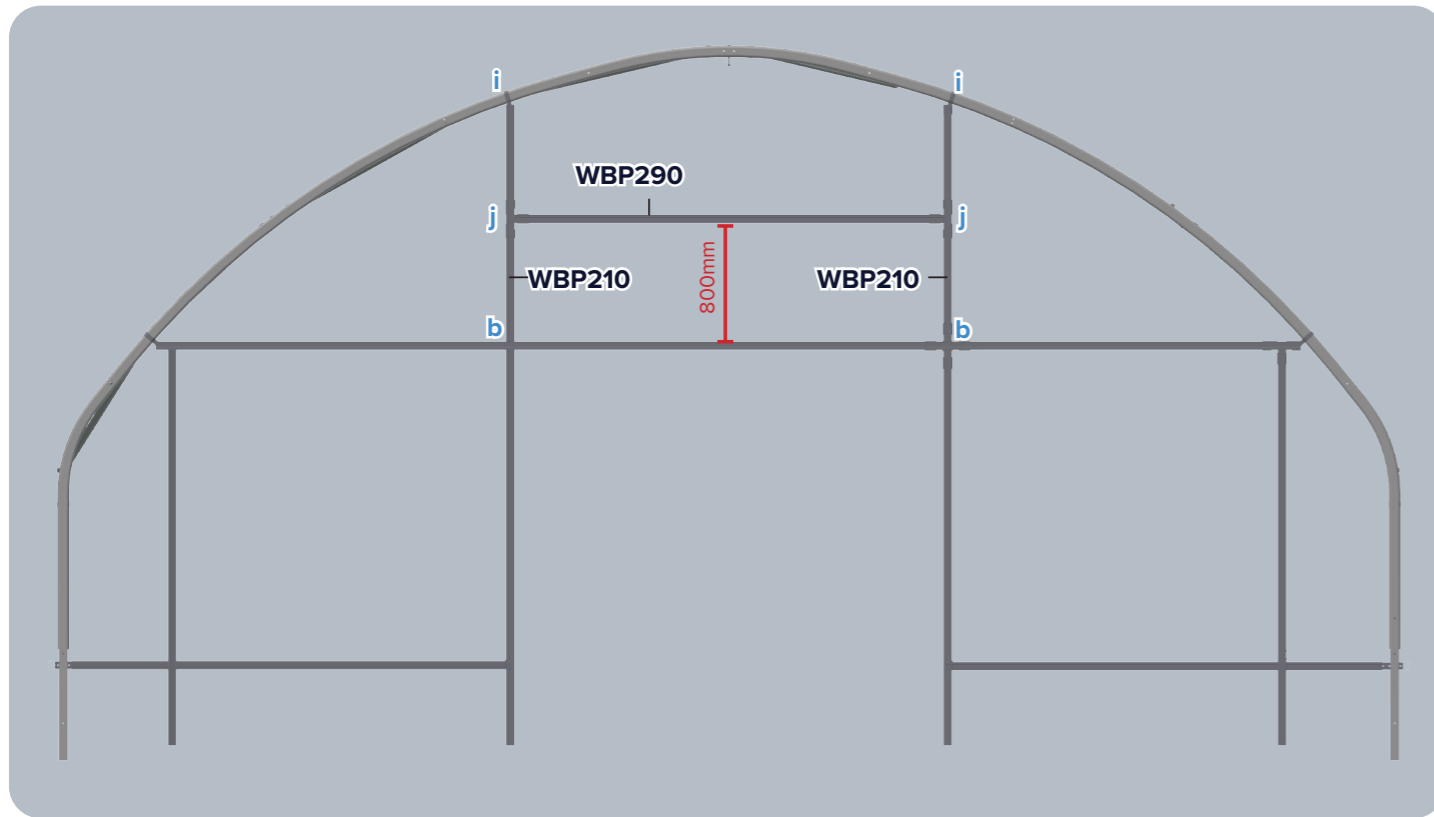

#### ⚠ If installing louvres

Install bracket to each H frame upright. Ensure correct orientation.

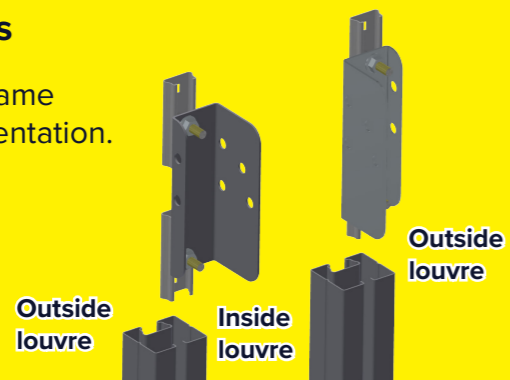

## Install Lintel Brace Bar

The lintel brace bar goes from the second hoop (H2) to the lintel at position **b**. Depending on your structure spec, position **b** will either be a T or cross bracket.

### Lintel Brace Bar Parts

Width	Lintel Brace Bar
5 metre	BBS094 + BBP160
6 metre	BBS098 + BBP160
7 metre	BBS060 + BBP160
8 metre	BBS083 + BBP160
9 metre	BBS081 + BBP183

#### 1. Assemble two part lintel brace bar

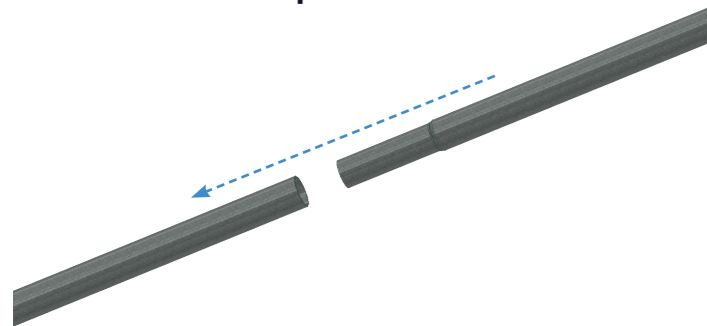

Connect two part lintel brace bar, and secure with a tek screw.

#### 2. Attach to hoop

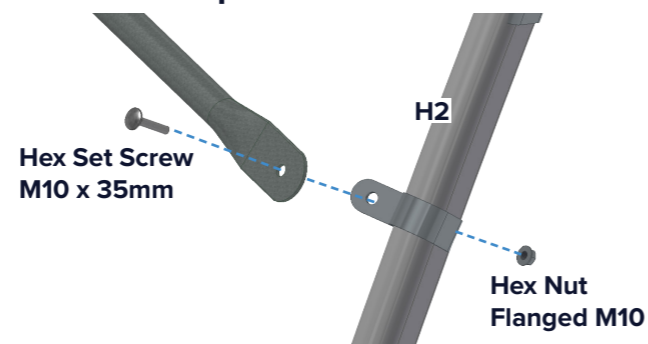

Attach lintel brace bar to hoop **H2**.

#### 3. Attach to lintel

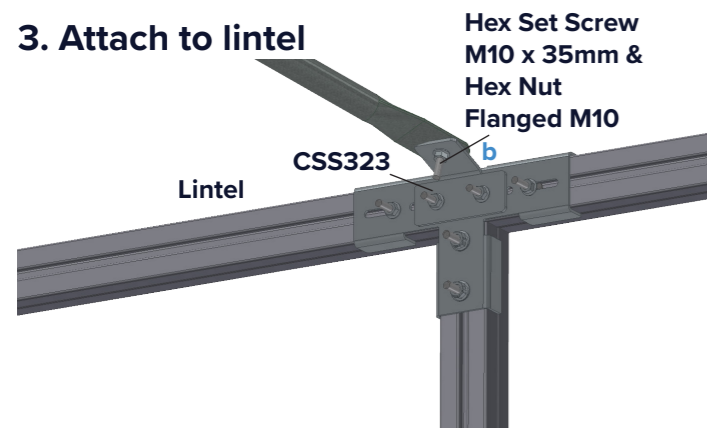

Attach to bracket (CSS323) at positions **b**.

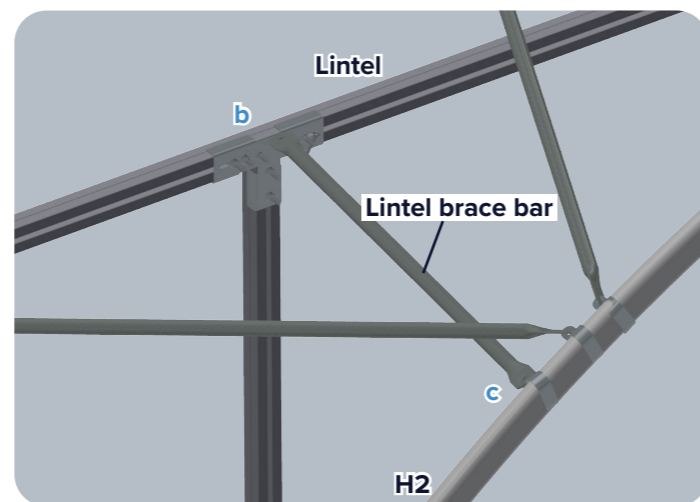

#### 4. Adjust lintel brace bar position

As you push the brace bar up and down the hoop it will push the end frame in and out.

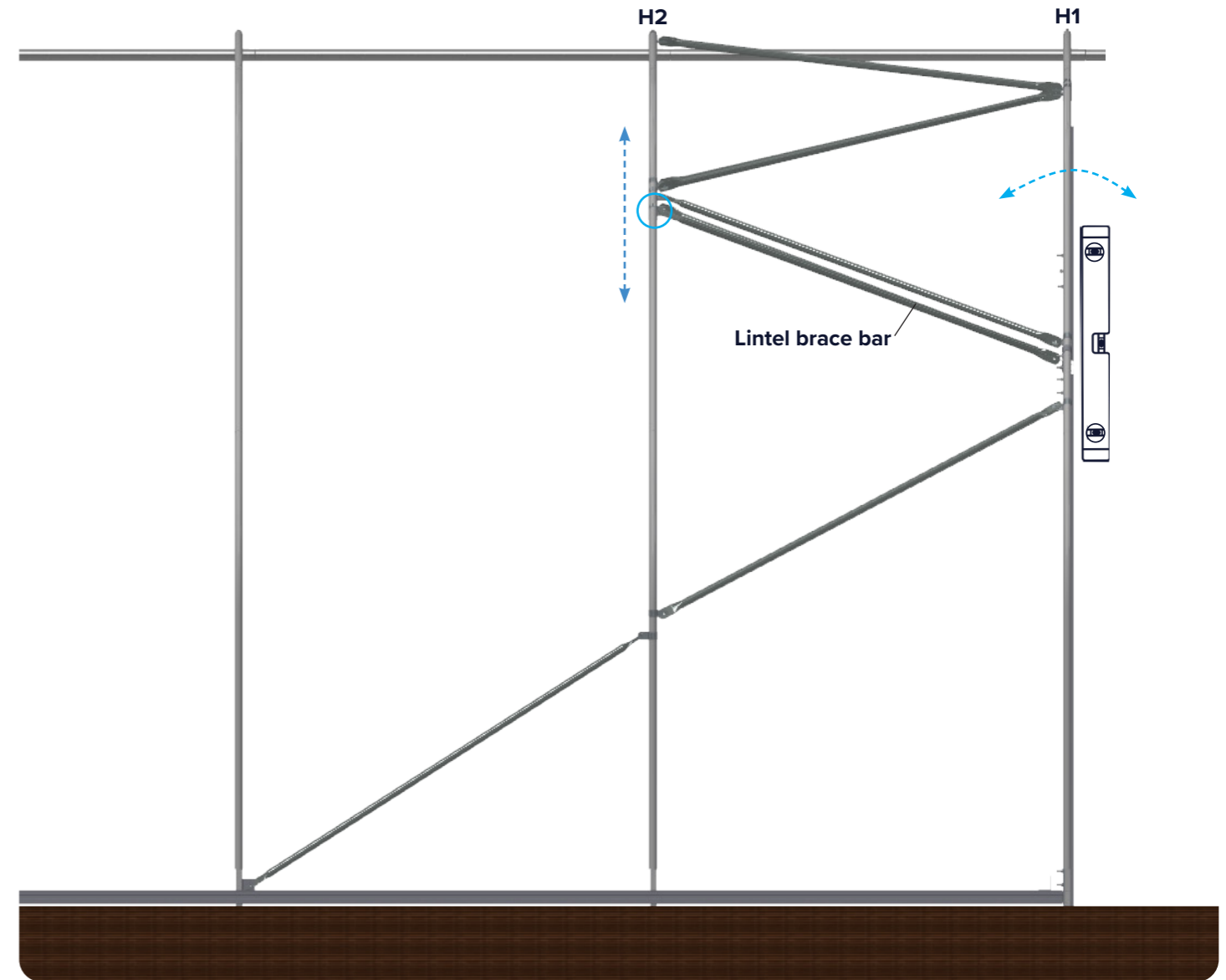

Crop Bar I Hanger Configuration

Width	Crop bar	A	B	C	D
5 metre	CBP217 CBP174	BBP036 BBS050	n/a	n/a	n/a
6 metre	CBP174 CBP291	BBP036 BBS075	n/a	n/a	n/a
7 metre	CBP291 CBP278	BBP036 BBS083	n/a	n/a	n/a
8 metre	CBP466 CBP174	BBP036 BBS098	n/a	n/a	n/a

1. Assemble two part hanger

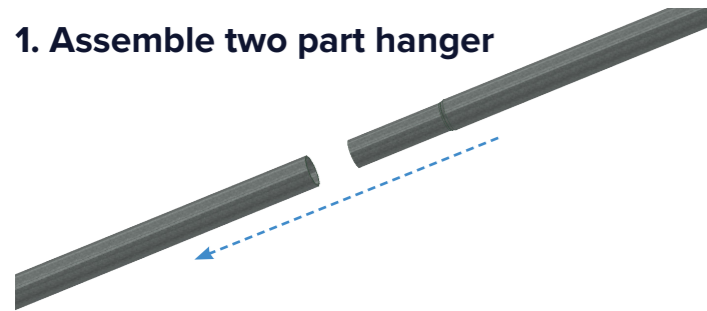

Connect two part hanger. Secure with a tek screw.

2. Assemble two part crop bar

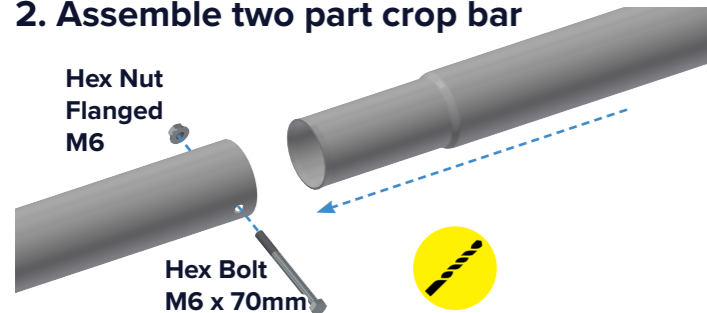

Connect two part crop bar. Drill and secure with nut and bolt.

3. Attach crop bar to hoop

At positions a.

4. Attach hanger to ridge bar

At position c.

5. Attach hanger to crop bar

At position b.

6. Repeat

Repeat for every inner hoop.

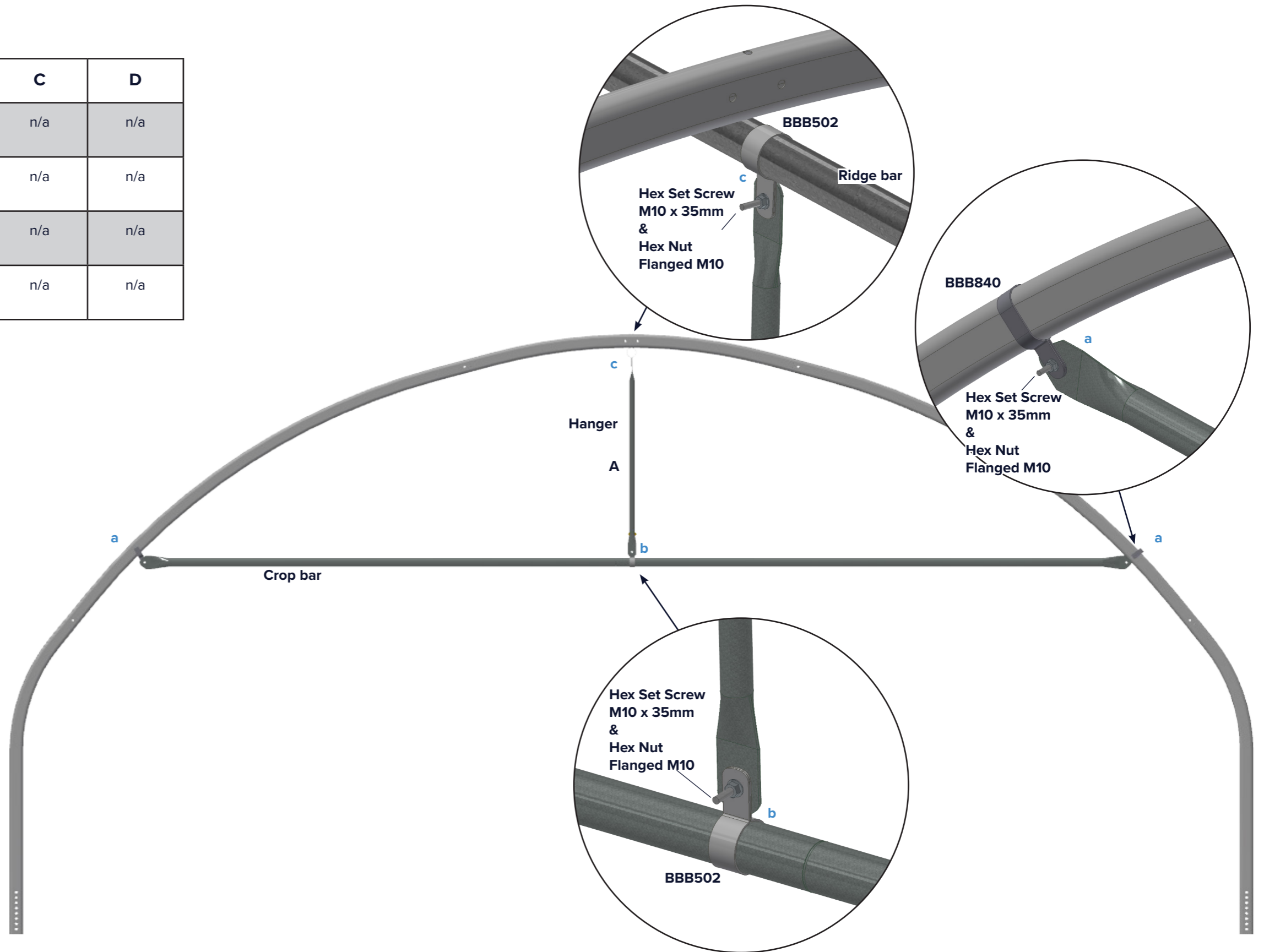

### Crop Bar V Hanger Configuration

Width	Crop bar	A	B	C	D
8 metre	CBP466 CBP174	n/a	BBP160 BBS030	n/a	n/a
9 metre	CBP466 CBP285	n/a	BBP160 BBS083	n/a	n/a

#### 1. Assemble two part hangers

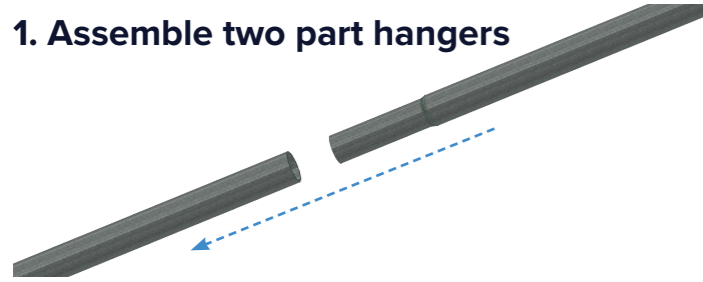

Connect two part hanger. Secure with a tek screw.

#### 2. Assemble two part crop bar

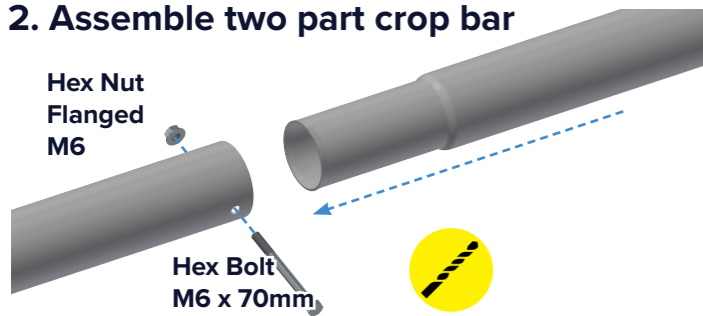

Connect two part crop bar. Drill and secure with nut and bolt.

#### 3. Attach crop bar to hoop

At positions a.

#### 4. Attach hanger to hoop

Attach hangers to the hoop (either side of the ridge bar) at position c using the the pre-drilled holes.

#### 5. Attach hanger to crop bar

At position b.

#### 6. Repeat

Repeat for every hoop.

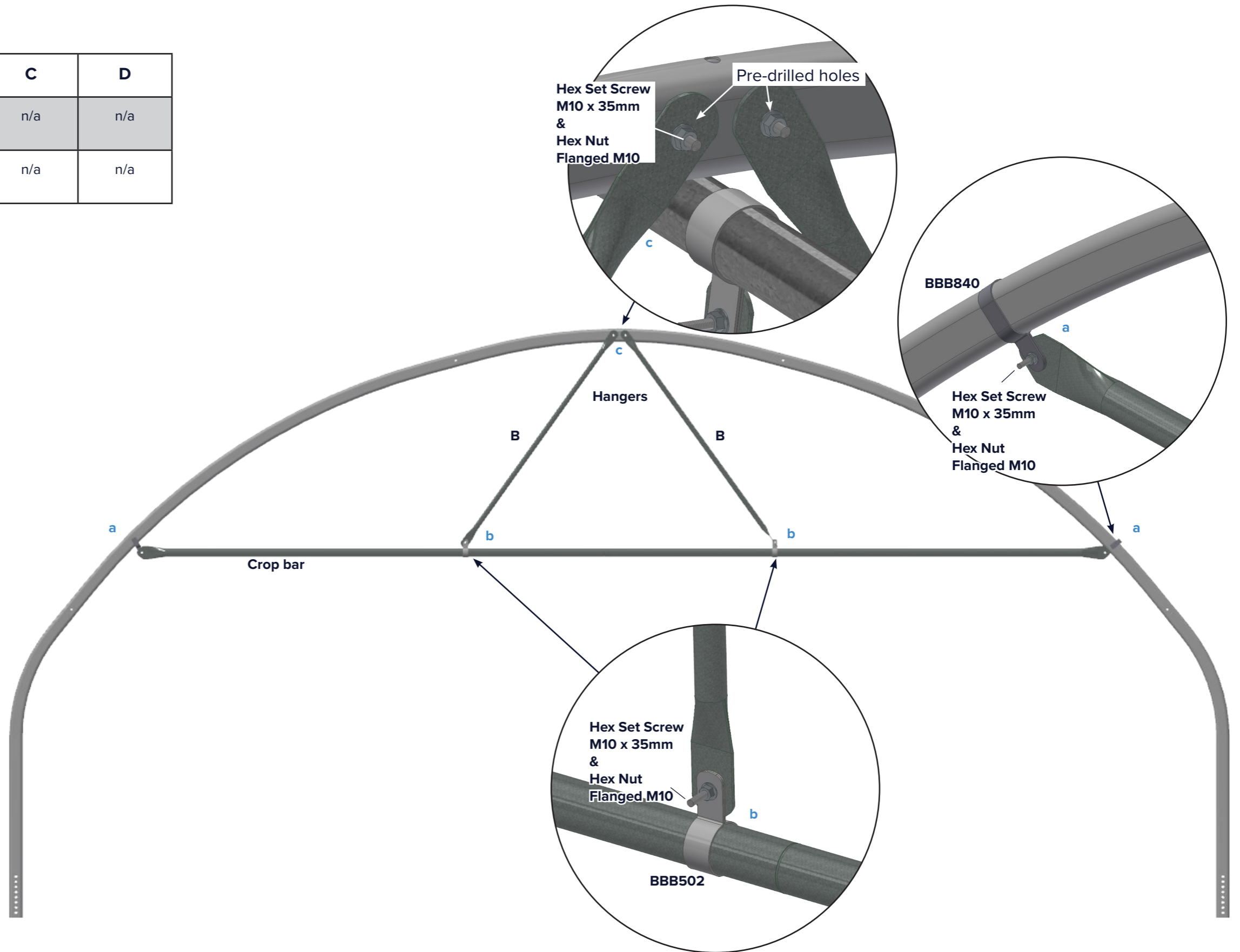

### Crop Bar W Hanger Configuration (Optional Haunches)

Width	Crop bar	A	B	C	D
9 metre	CBP466 CBP285	n/a	BBP160 BBS083	CBH132	CBH160

#### 1. Assemble two part hangers

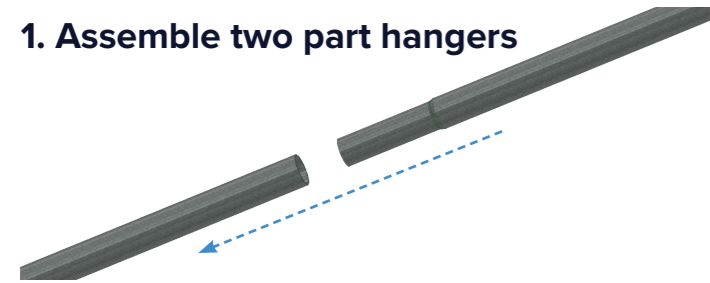

Connect two part hanger. Secure with a tek screw.

#### 2. Assemble two part crop bar

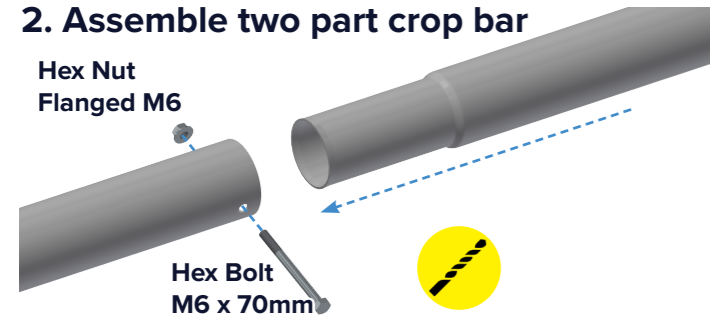

Connect two part crop bar. Drill and secure with nut and bolt.

#### 3. Attach crop bar to hoop

At positions a.

#### 4. Attach hanger to hoop

Attach hangers to the hoop (either side of the ridge bar) at position c using the the pre-drilled holes.

#### 5. Attach hanger to crop bar

At position b.

#### 6. Attach hanger to hoop

At positions d.

#### 7. Attach haunches (if applicable)

At positions f.

#### 8. Repeat

Repeat for every hoop.

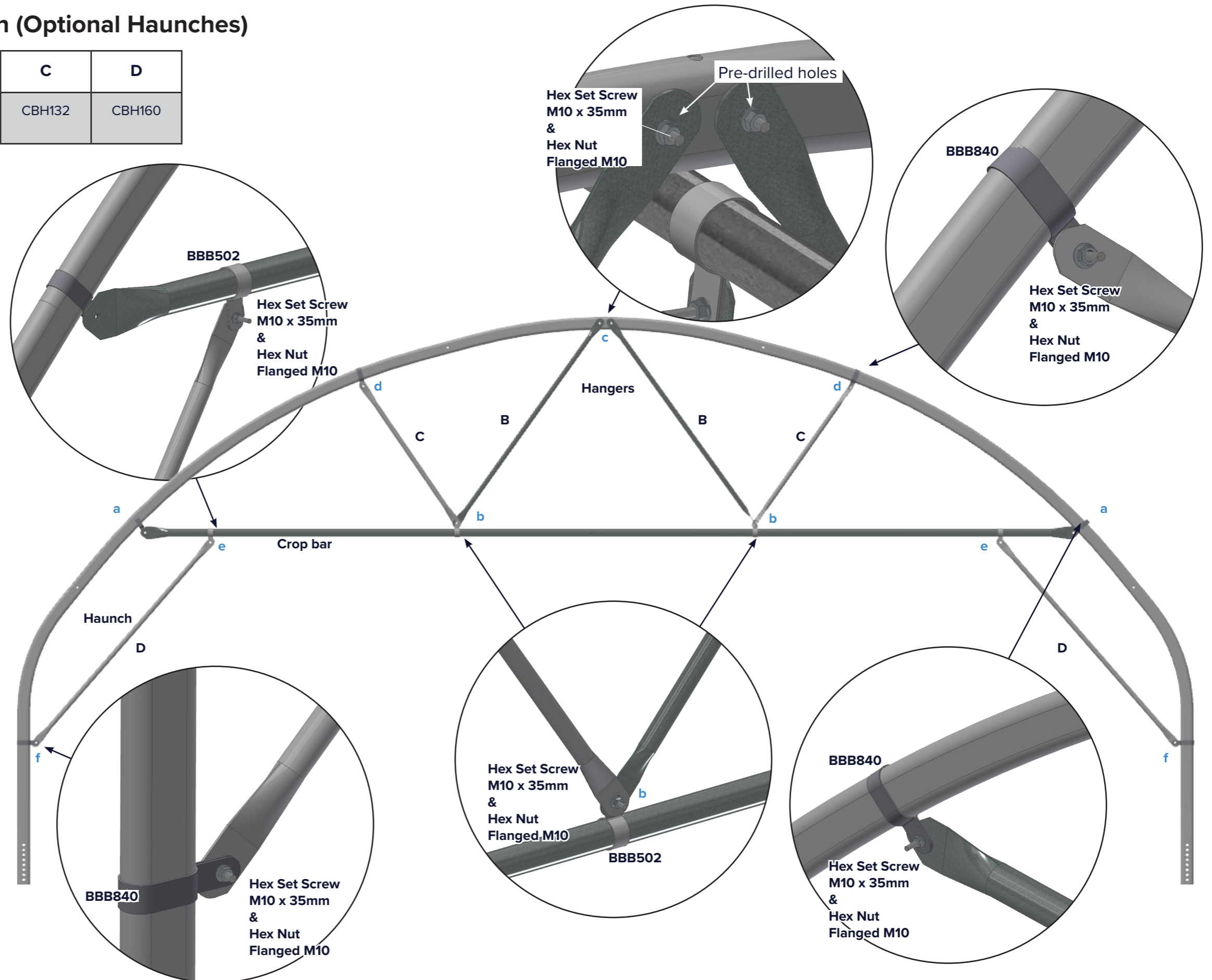

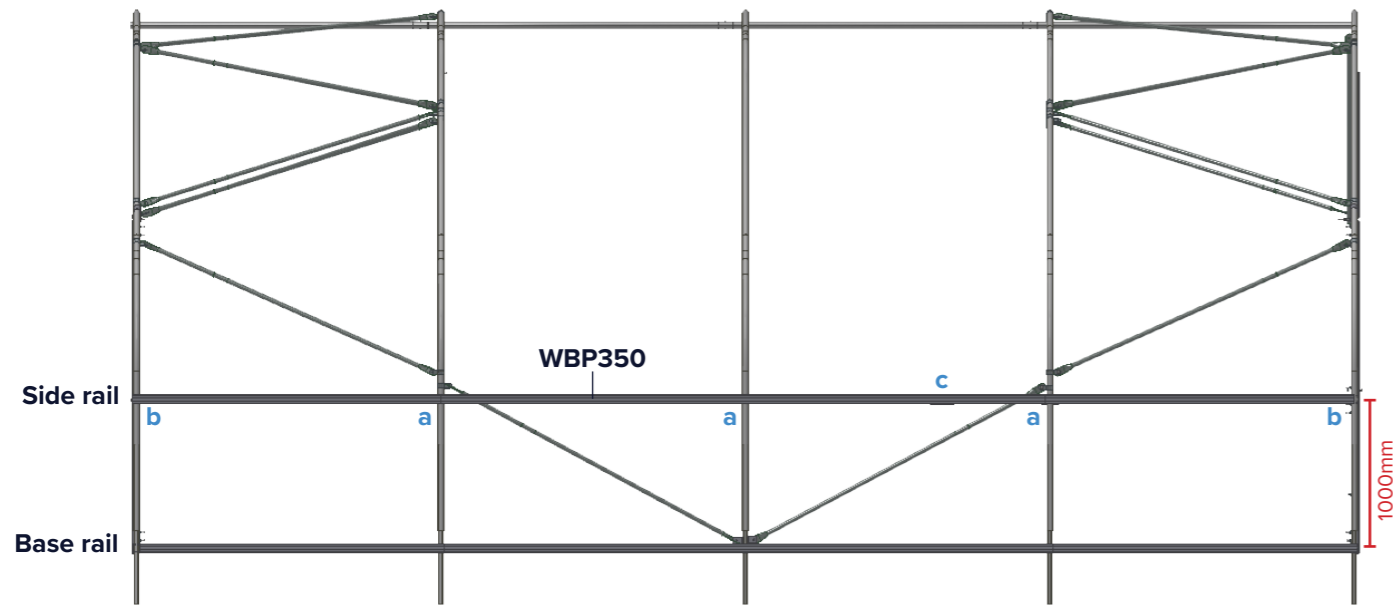

If your tunnel has side rails, proceed with the following steps.

**1. Assemble side rail bracket**

Loosely assemble side rail bracket around hoop at position **a**.



**2. Finger tighten**

Finger tighten to hold in position, at around 950mm from the base rail.

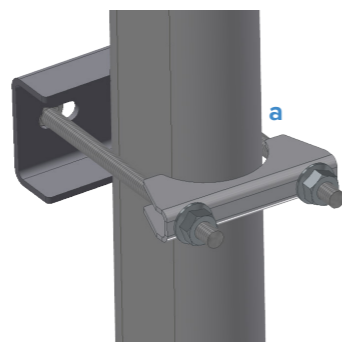

**3. Attach side rail to hoops**

Starting at one end of the tunnel. Slide side rail profile onto the cotter and bracket at each hoop - pushing the first piece of profile into the corner bracket.

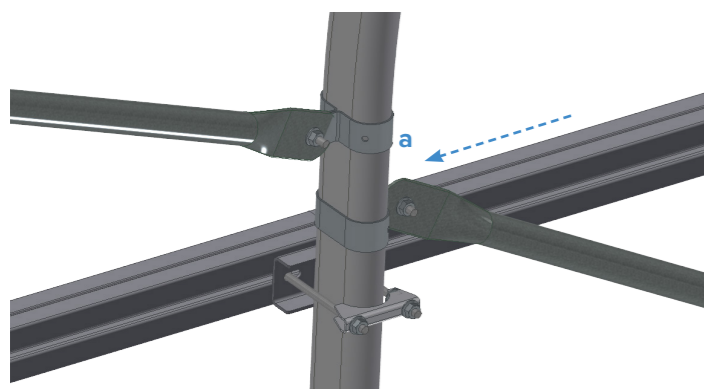

**4. Attach to side rail to corner brackets**

At each corner (**b**) attach the profile to the corner bracket.

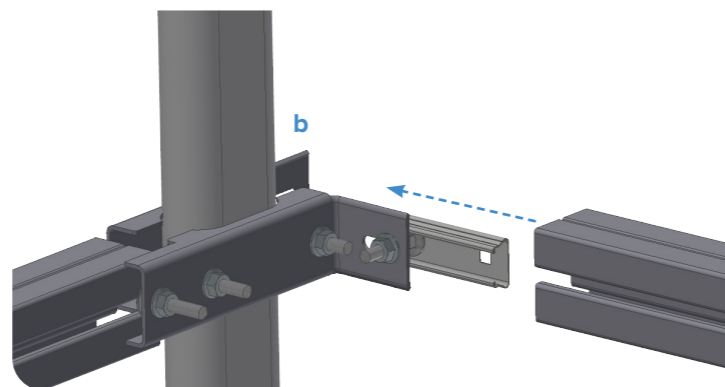

**5. Join side rail lengths**

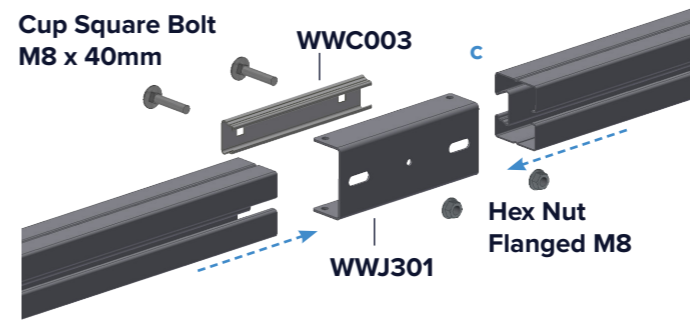

Where side rail profile pieces join, connect them with a bracket.

**6. Tighten up**



Tighten side rail to form a continuous side rail the full length of the tunnel.

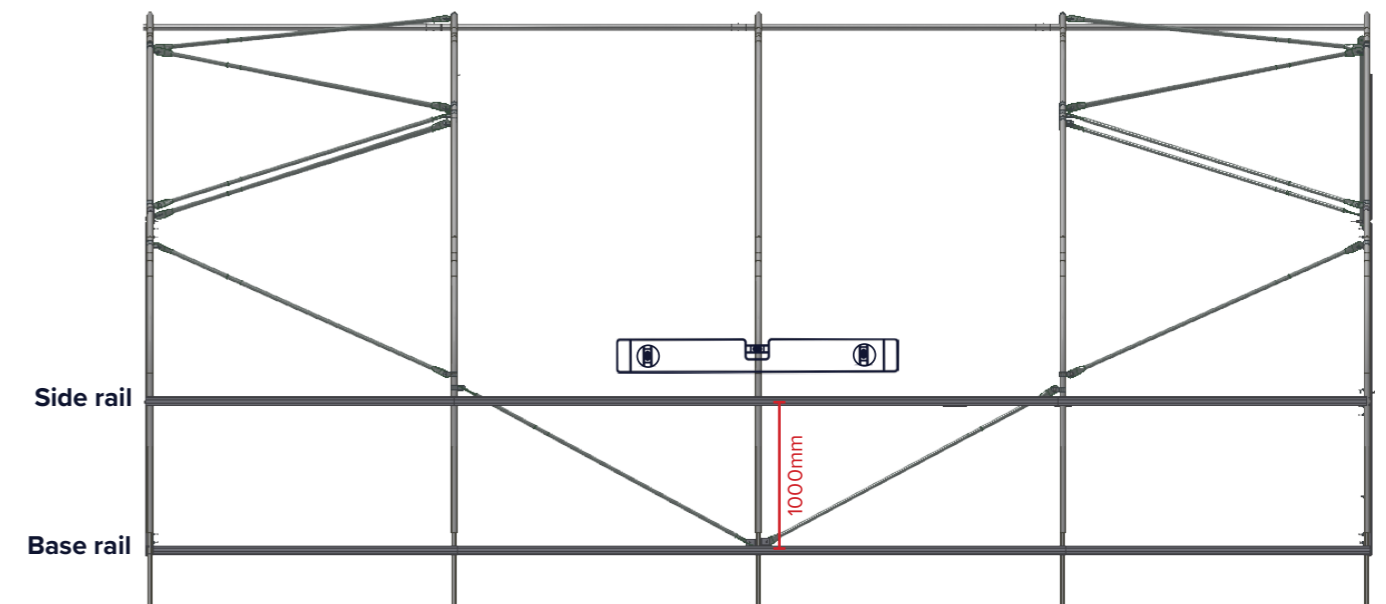

**7. Check levels and tighten**

Finish side rail assembly by checking level. Ensure distance from base rail is 1000mm (from centre to centre of profile). Tighten all nuts and bolts.

Repeat on sides with side vents.

### Installing Curtain

If installing curtain, proceed with the following steps.

**1. Attach keder profile (KDP001)**

Fix to inside of side rail using tek screws.

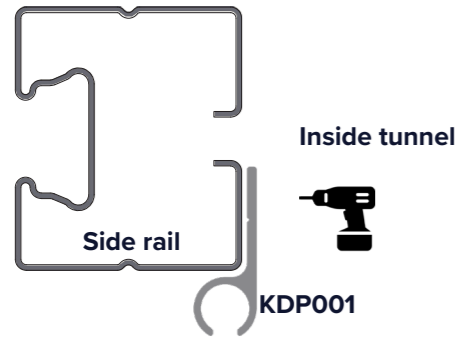

**3. Feed PVC curtain into keder profile**

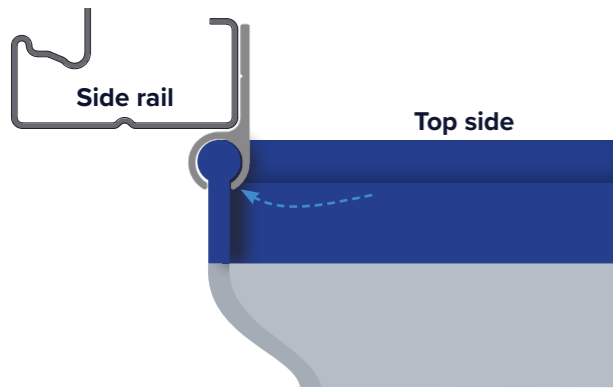

**5. Cut away excess curtain**

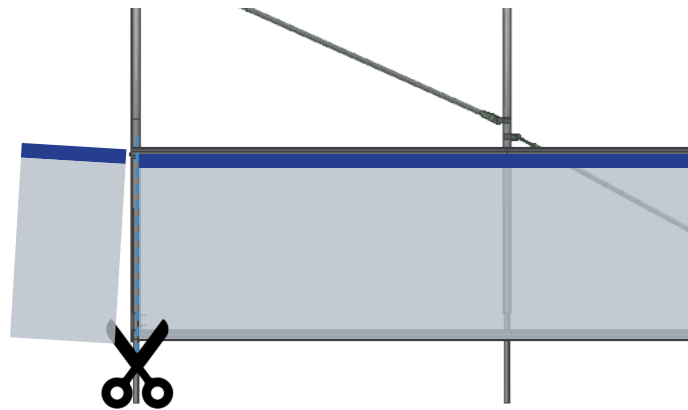

**2. Assemble drive tube**

Use drive tube joiners and fix with tek screws. Cut to final length.

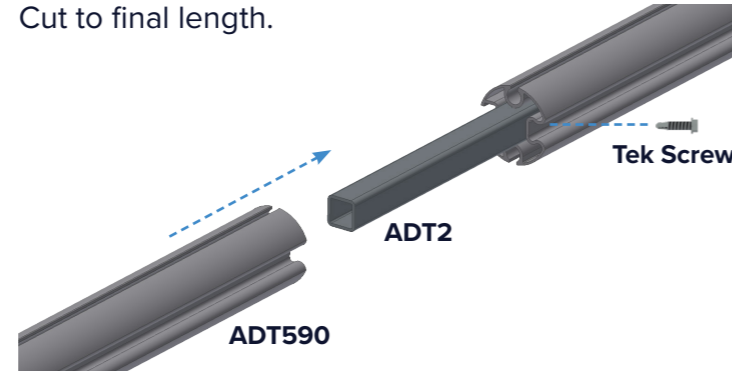

**4. Feed curtain onto drive tube**

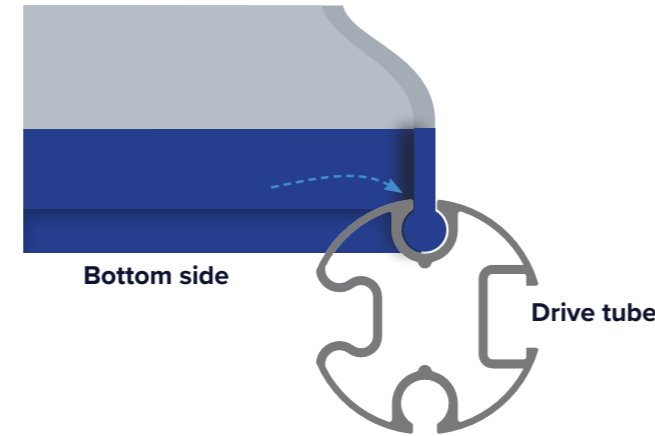

### Manual Winder

**1. Attach bottom bracket (SVB001)**

Slide bottom bracket onto winch tube and fasten with a tek screw.

**2. Slide on manual winder (MWD001)**

Onto winch tube.

**3. Attach top bracket (SVB002)**

Onto winch tube.

**4. Attach drive tube adapter (SVA093)**

Fix in place with a bolt.

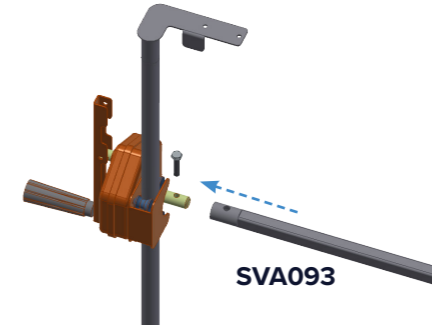

**5. Fit manual winder assembly to drive tube**

Attach manual winder assembly to the structure. Slide drive tube adapter into drive tube and fix winder assembly to base rail and side rail with two tek screws.

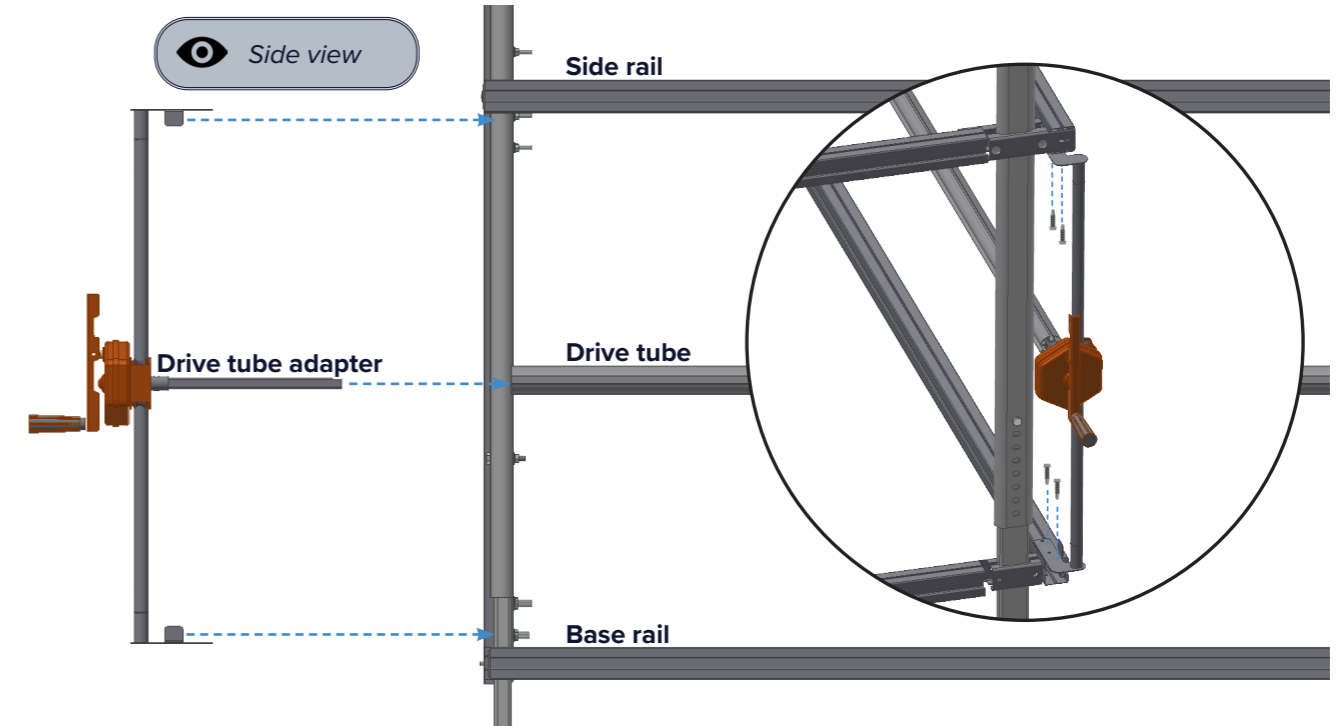

**6. Test operation and leave in rolled up position**

**Final Assembly**

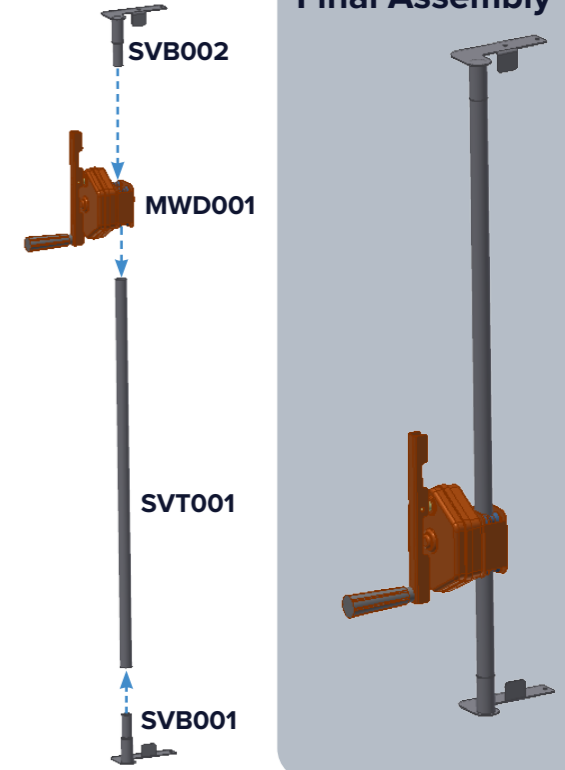

## Motorised Winder

### 1. Attach wiggle wire channel

Fix with tek screw to base rail. Use nut and bolt (nut facing inside tunnel)

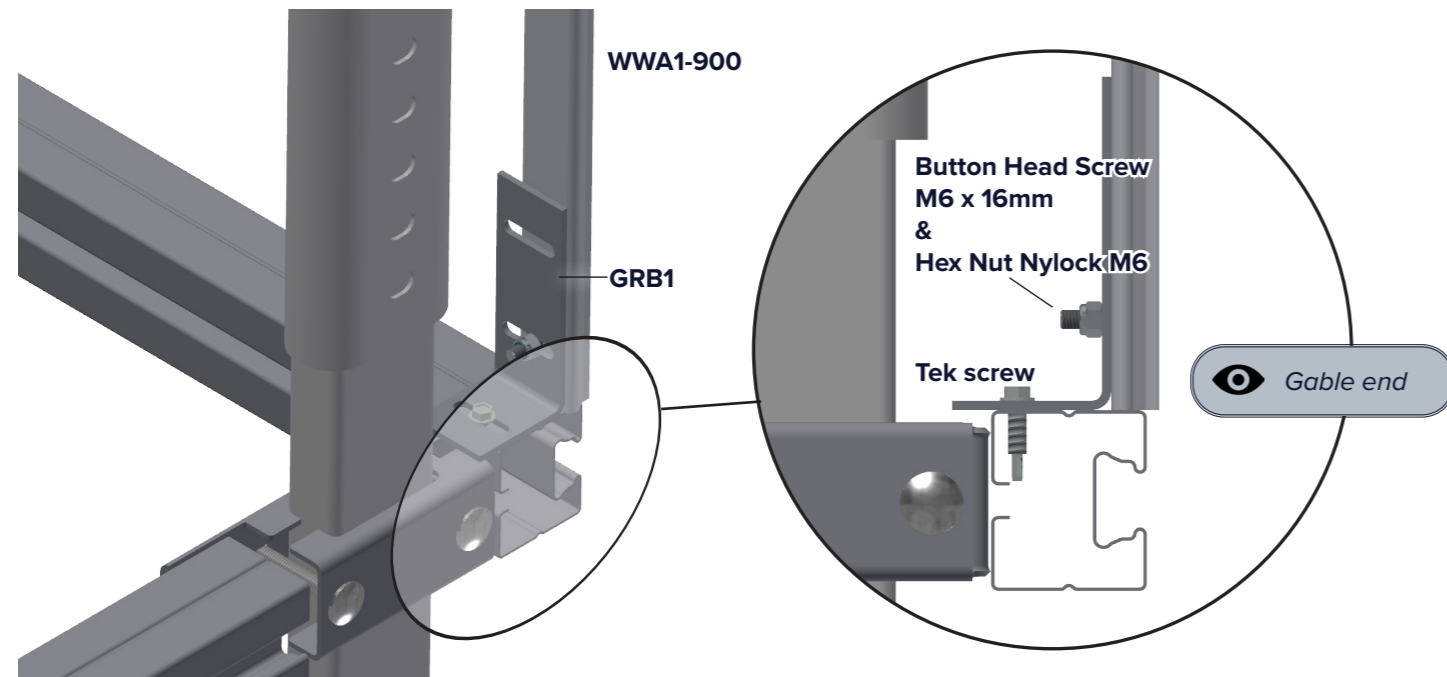

### 2. Assemble motorised winder

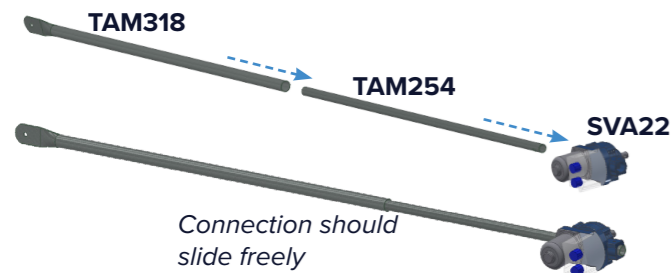

### 3. Fix motor to arm

Align holes with tube and secure with bolt.

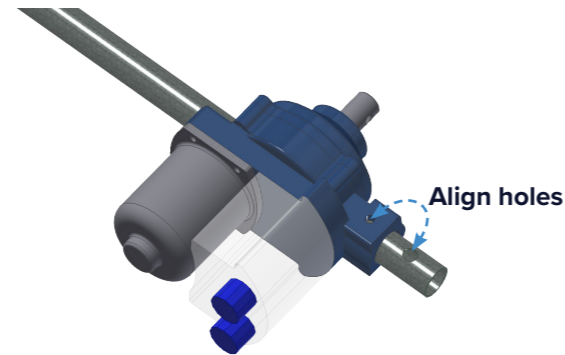

### 4. Attach drive tube adapter

Fasten with bolt.

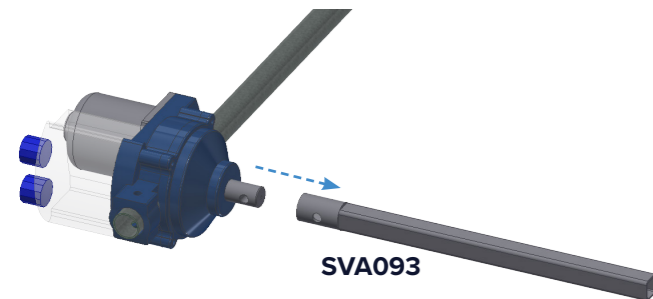

### 5. Connect motor to drive tube

Slide onto drive tube and fix with tek screw.



### 7. Attach arm to base rail

Lay motor assembly on the floor with telescopic arm in shortest position. Mark position **a** on base rail and drill hole. Fix telescopic arm with nut and bolt. The middle connection should slide freely.

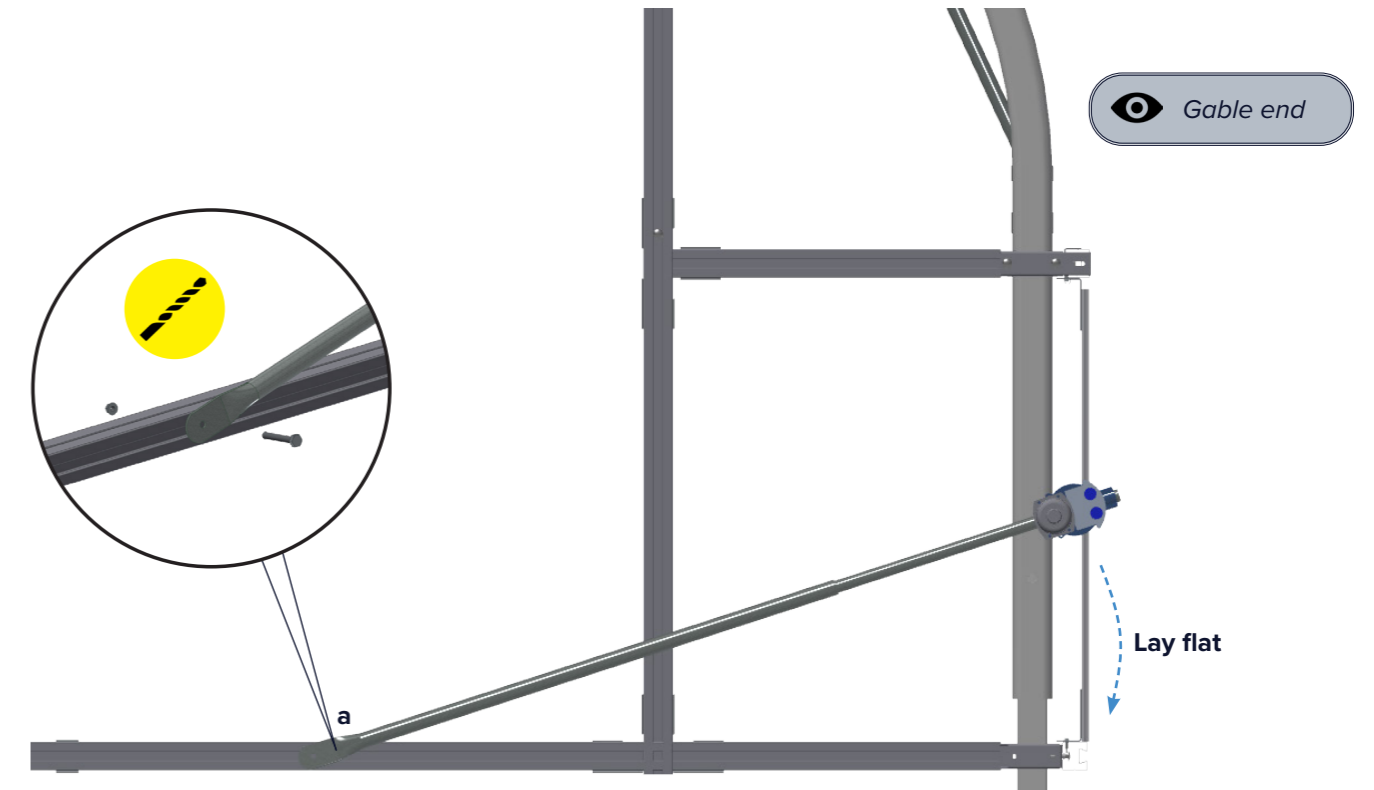

### 8. Test operation and leave in rolled up position

**Before fixing side vent netting, install wiggle wire profile uprights, if not already in place.**

**For ends with curtain winder**

Attach a length of wiggle wire channel to the winder assembly bracket using tek screws.

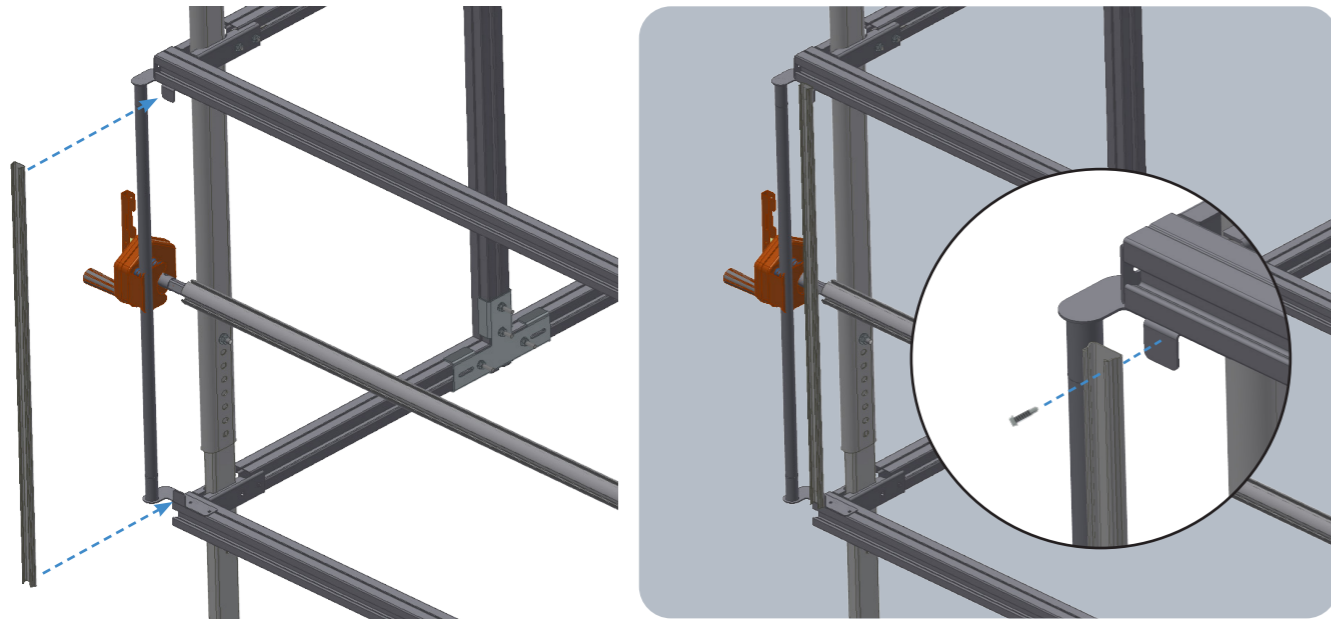

**For ends without curtain winder**

Attach a length of steel profile between the side rail and base rail. Use L bracket and tek screws to fix to rails.

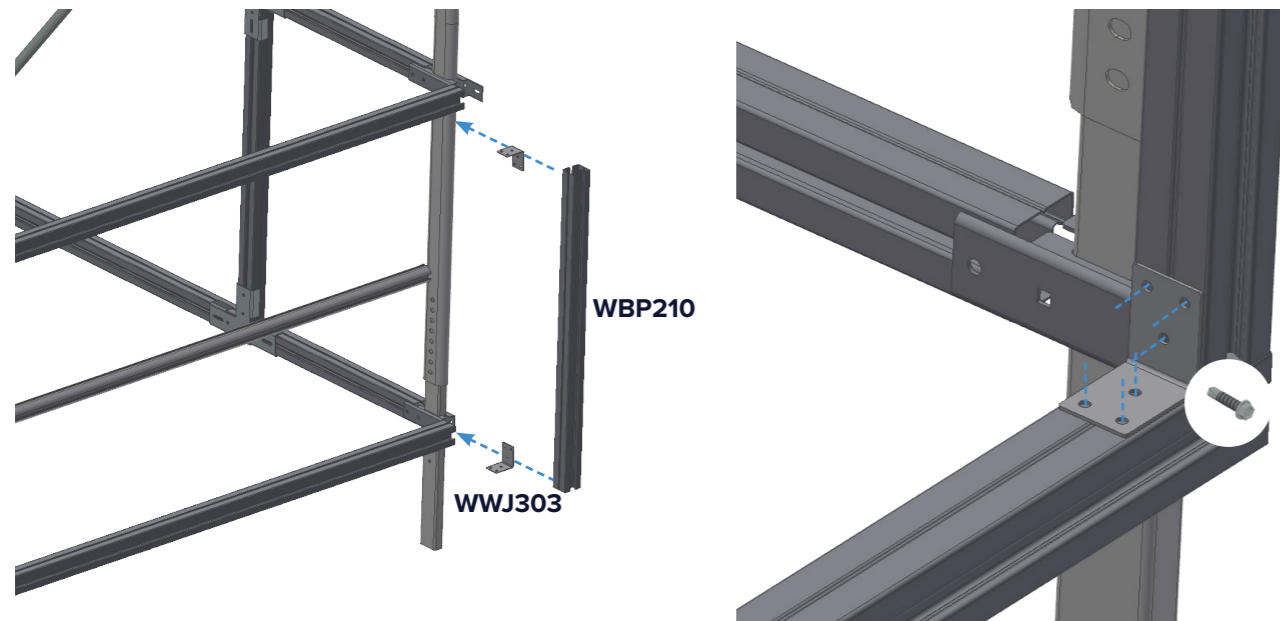

**!** If you've installed a curtain. Ensure curtain is in rolled up position before fitting net.

**1. Fit draught exclusion panels**

Install one for either end of curtain.

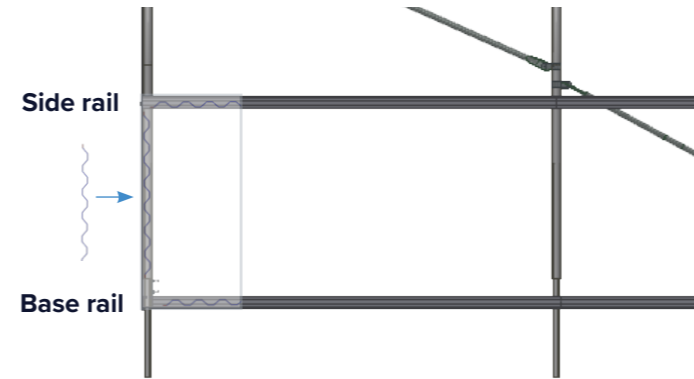

**2. Position net and hold in place**

Attach either end with a piece of wiggle wire pulling tight down the length.

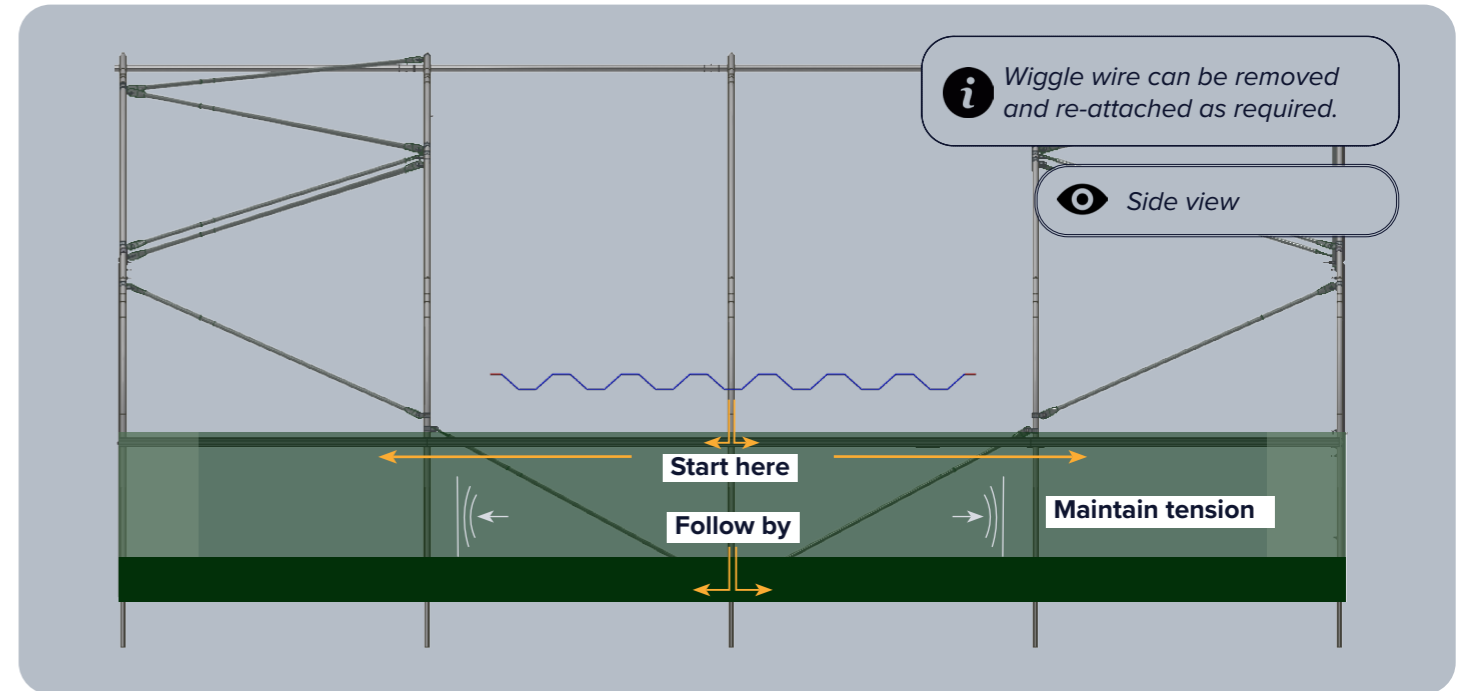
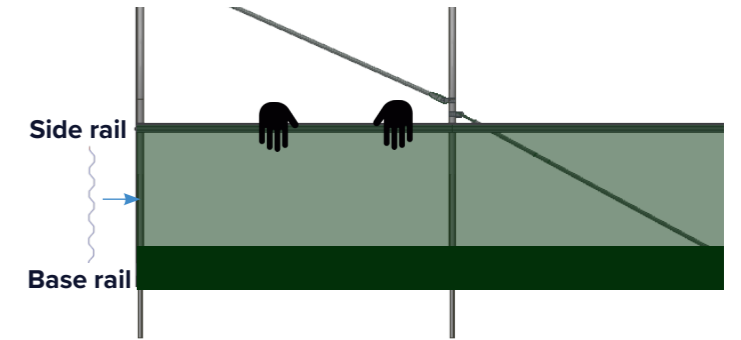

**3. Attach net with wiggle wire**

Start from the centre of the side rail working outwards. Then attach to the base rail.

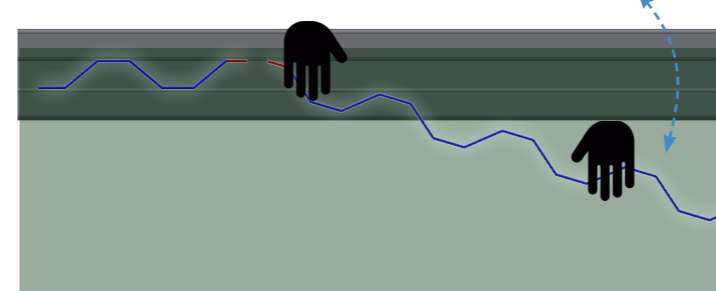

**4. Cut wiggle wire to length**

Using a pair of wire snips.

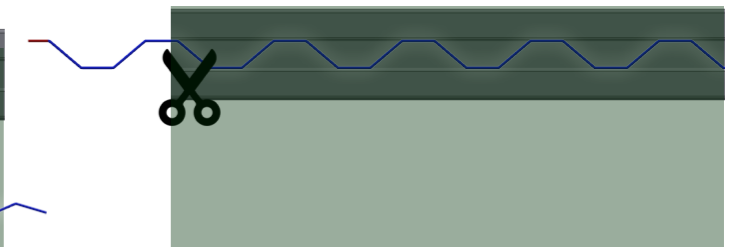

Please refer to instructions INS440, INS388, and INS068

### 1. Mark C channel every 600mm

Use tape or a marker pen.

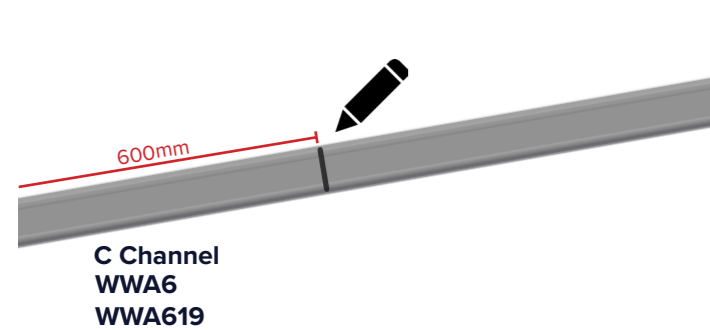

### 2. Slide channel mounting brackets

Onto C Channel. One for each mark.

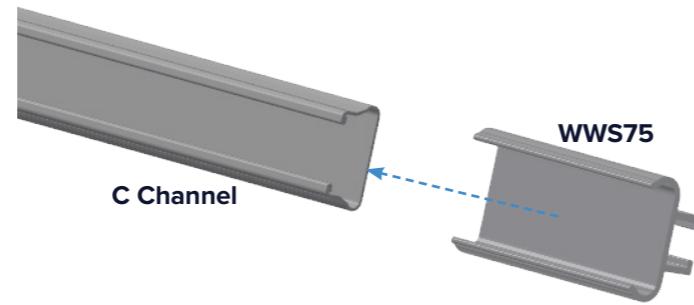

### 3. Attach C channel to hoop

Slide channel mounting brackets onto exhaust clamps bolt head while clamping to hoop. Bend the C channel to follow the hoop shape.

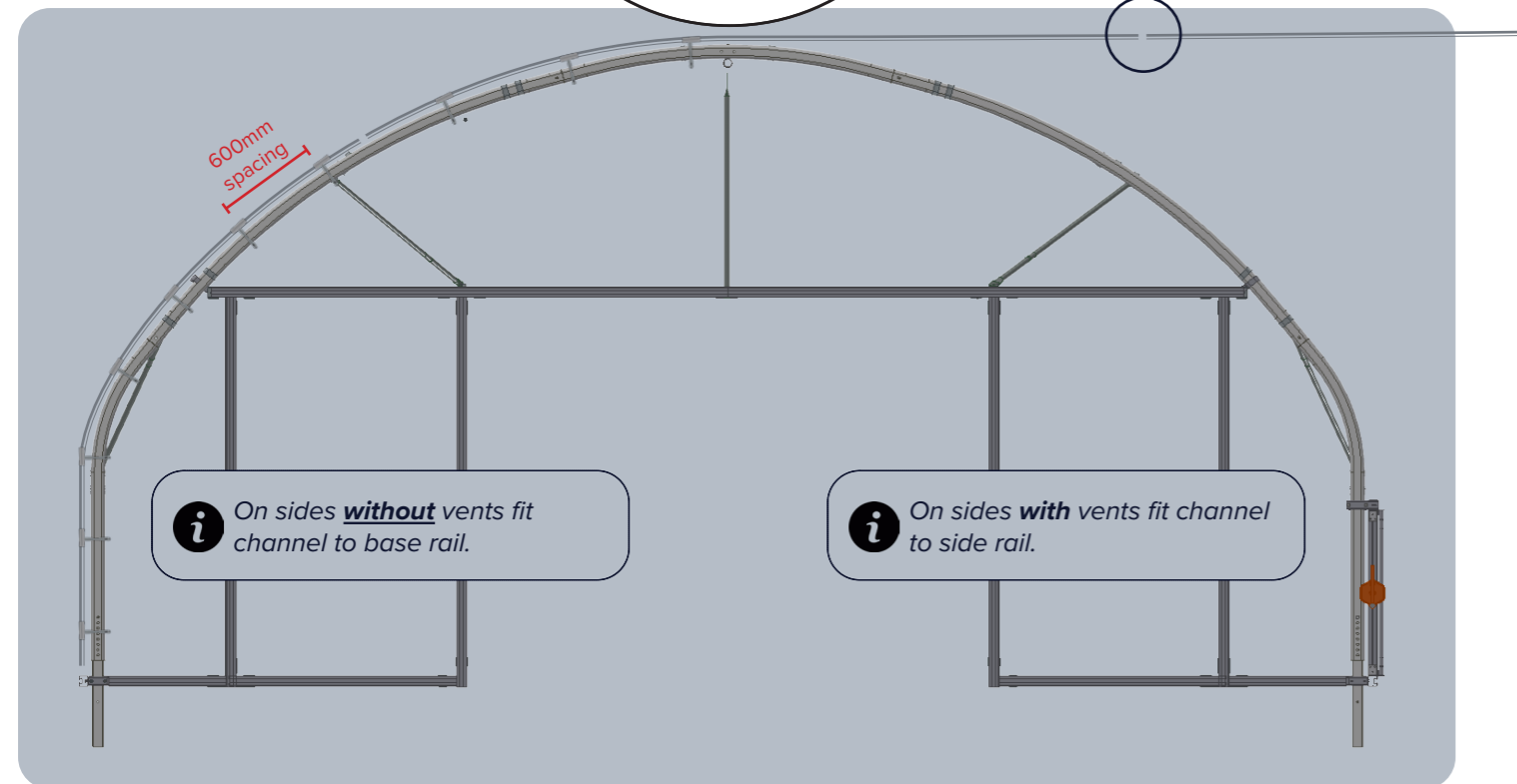
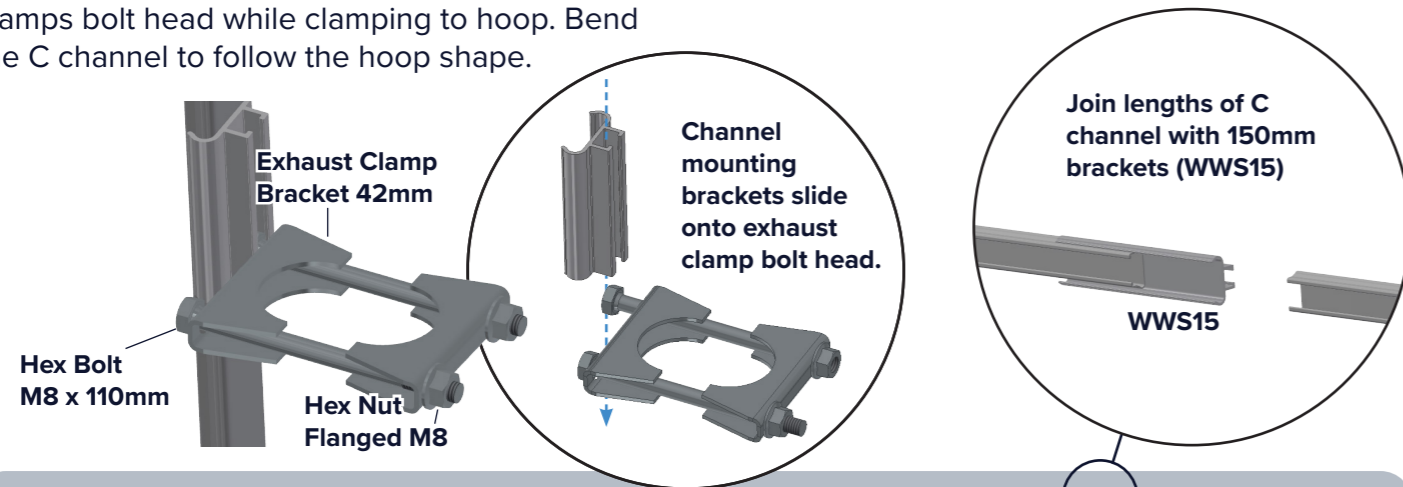

Assemble Louvre

1. Slide brackets onto outer uprights

Ensure correct orientation.

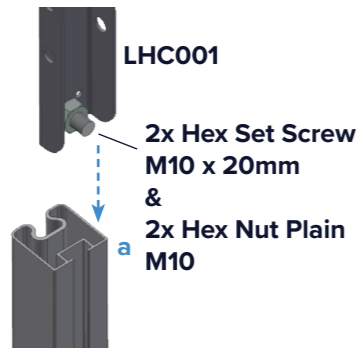

2. Slide bracket onto centre upright

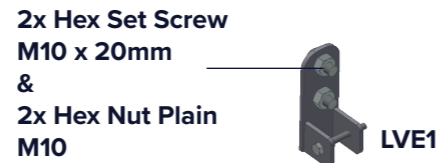

3. Complete frame using corner and T joiners

Use mallet to secure.

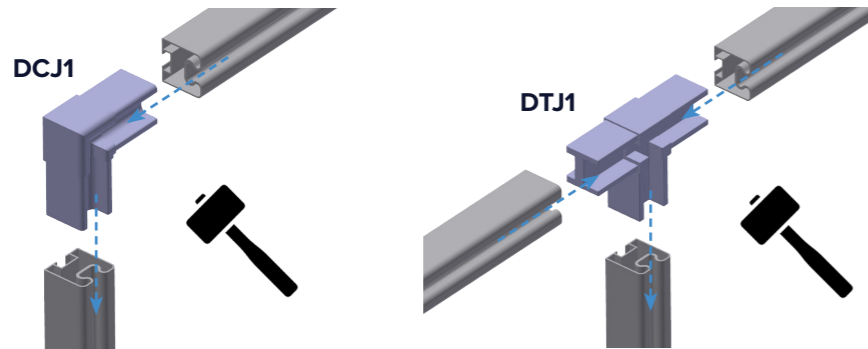

Final Assembly

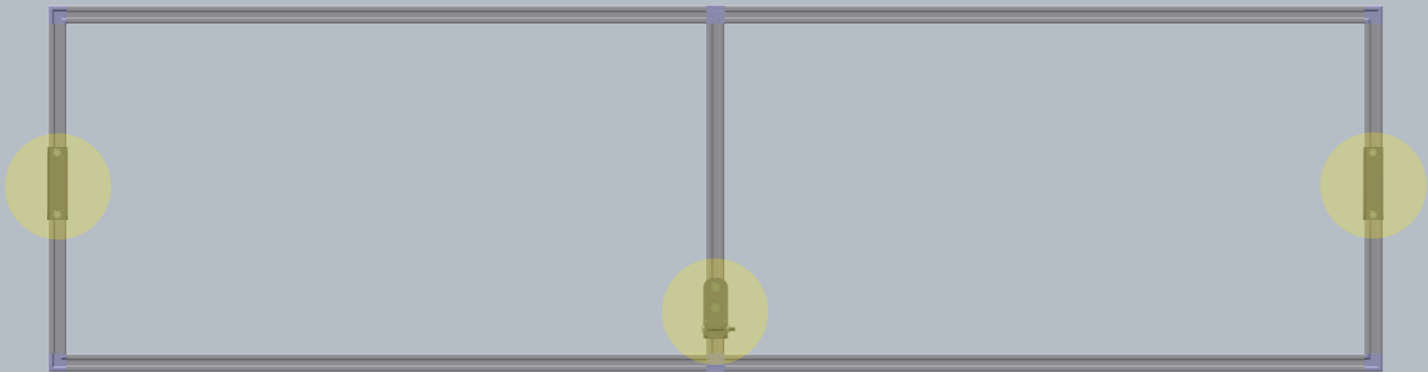

Roughly position brackets (highlighted) and leave finger tightened to allow for adjustment.

Cover Louvre

1. Roughly cut polythene to size

Allow approximately 30cm excess of polythene on all sides to allow for U profile to be pushed into position.

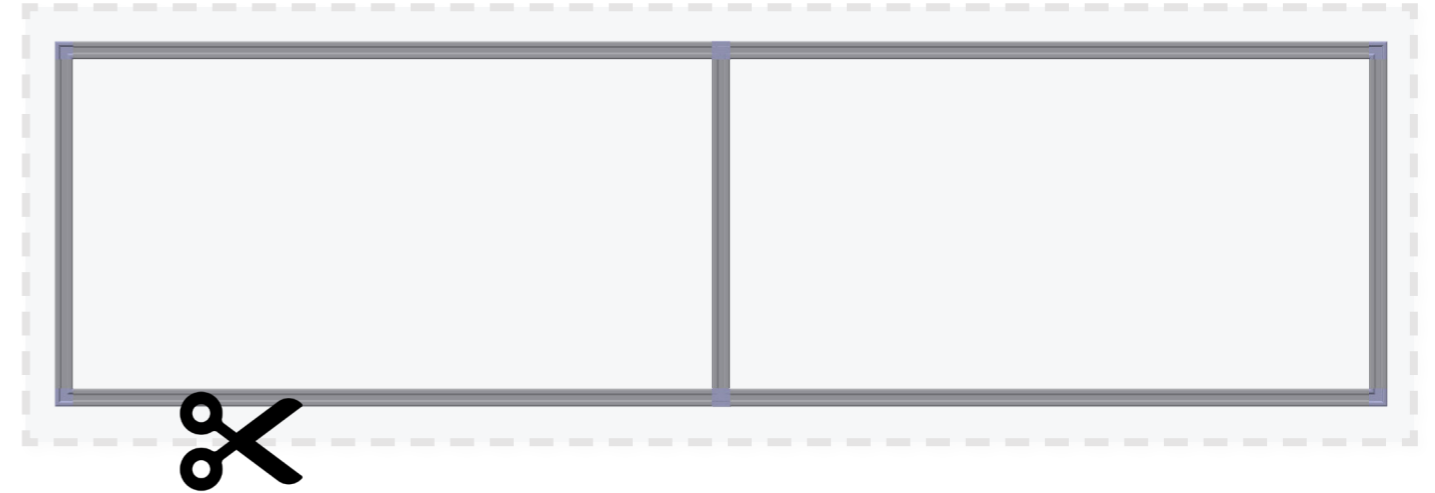

2. Fix polythene to frame

Attach polythene to frame perimeter using ali trap, ensuring polythene is tight. See below for guidance using ali trap.

**!** Do not fix polythene to centre upright.

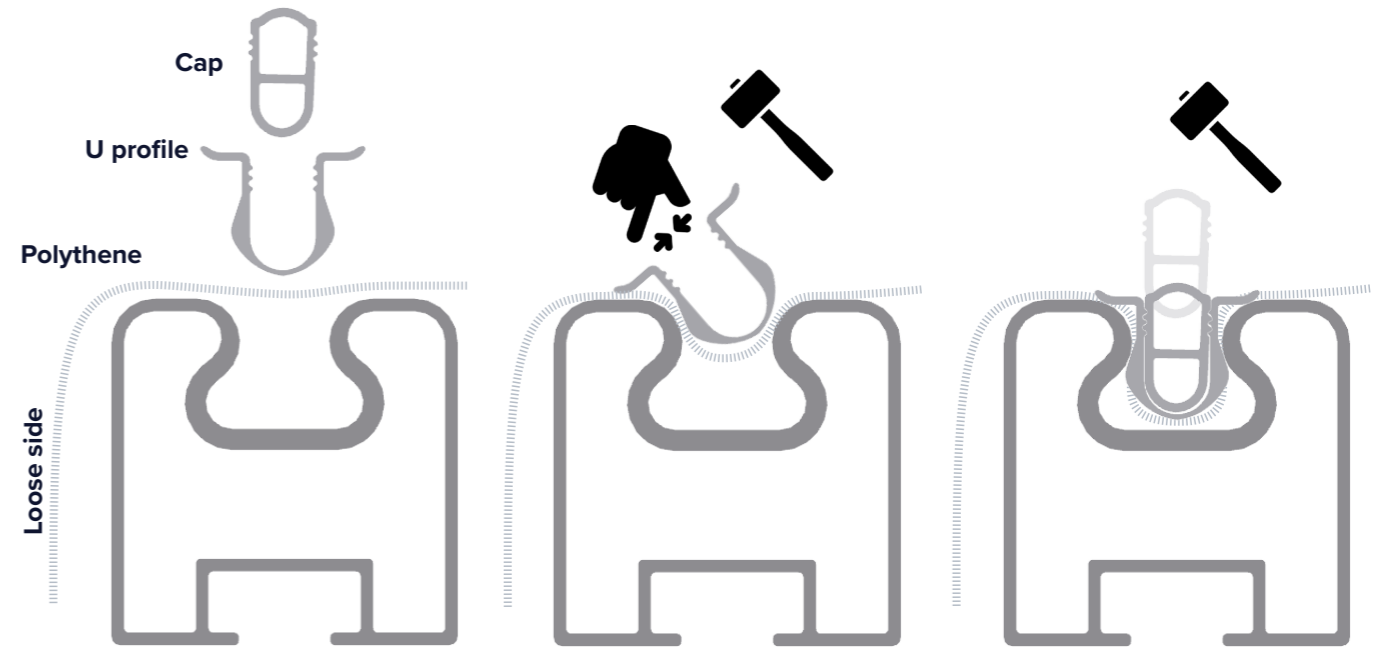

### Attach Louvre to H Frame

#### 1. Use bolt to connect brackets at pivot point

Ensure both pivot points are at the same height (a).

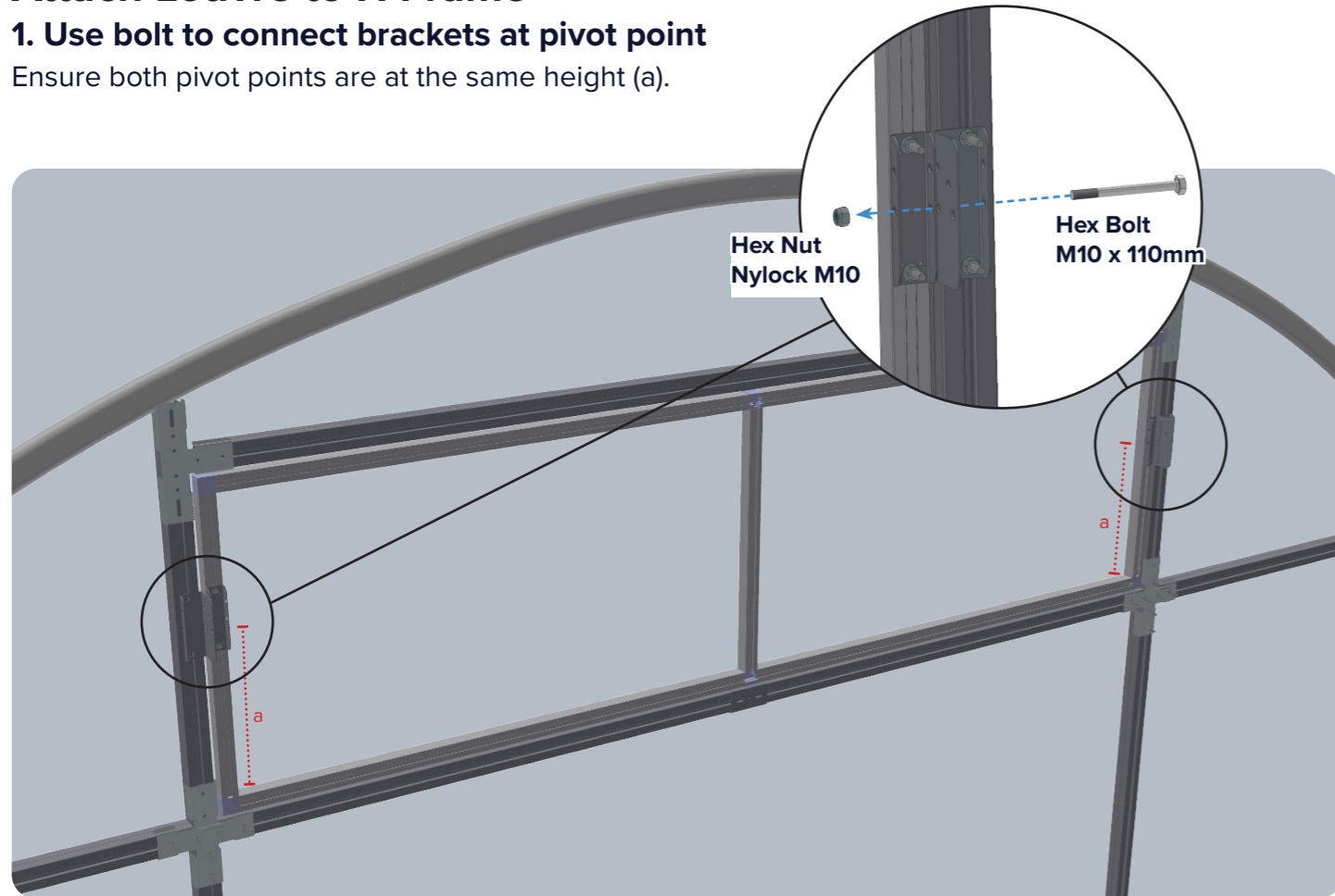

#### 3. Slide rack into motor assembly

#### 4. Attach rack to louvre bracket

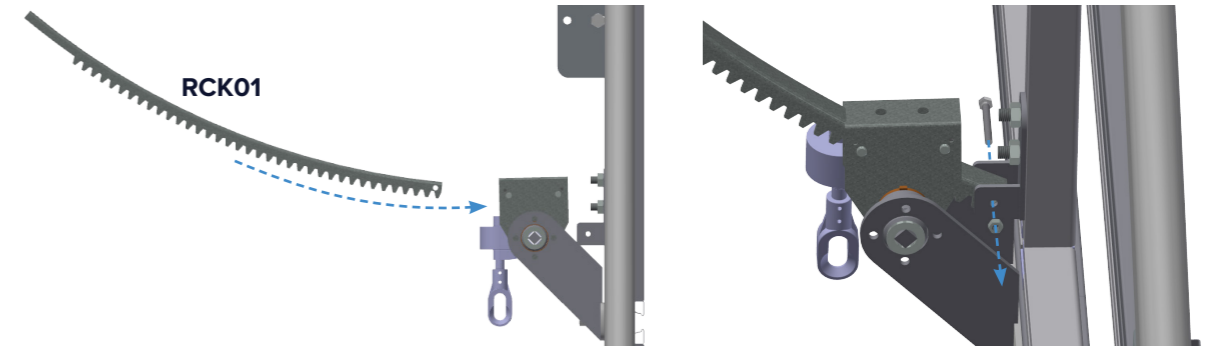

### Connect Rack and Pinion

#### 1. Attach bracket to lintel

#### 2. Assemble motor

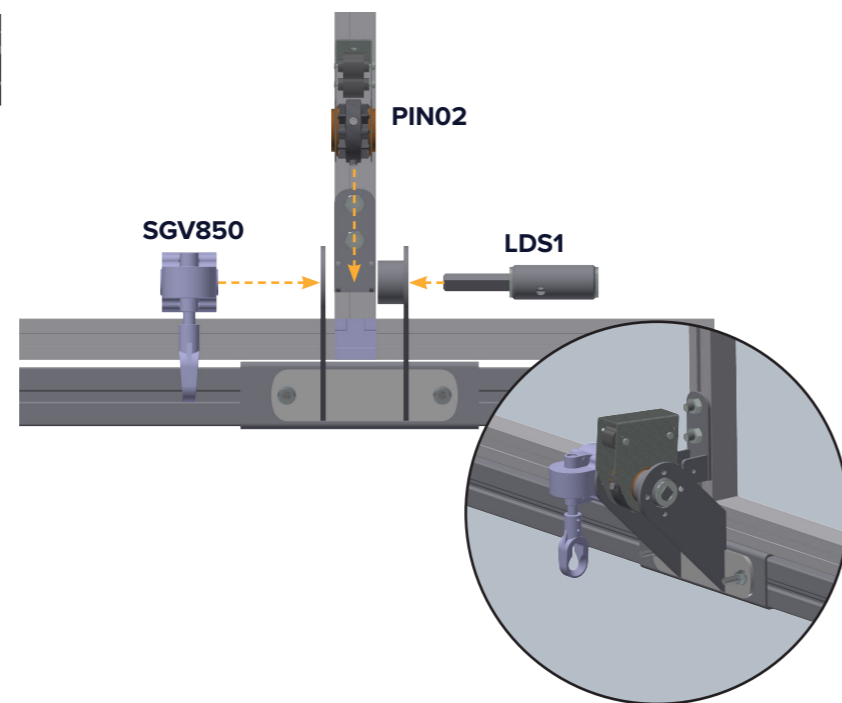
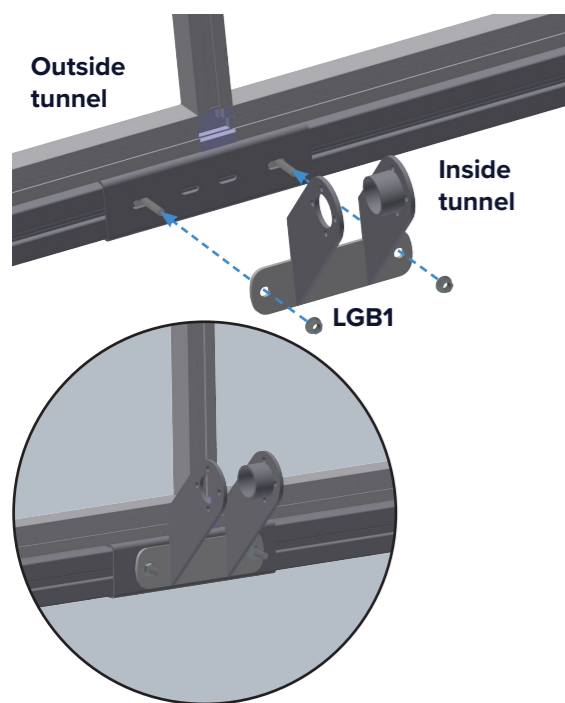

### Final Assembly

Top view

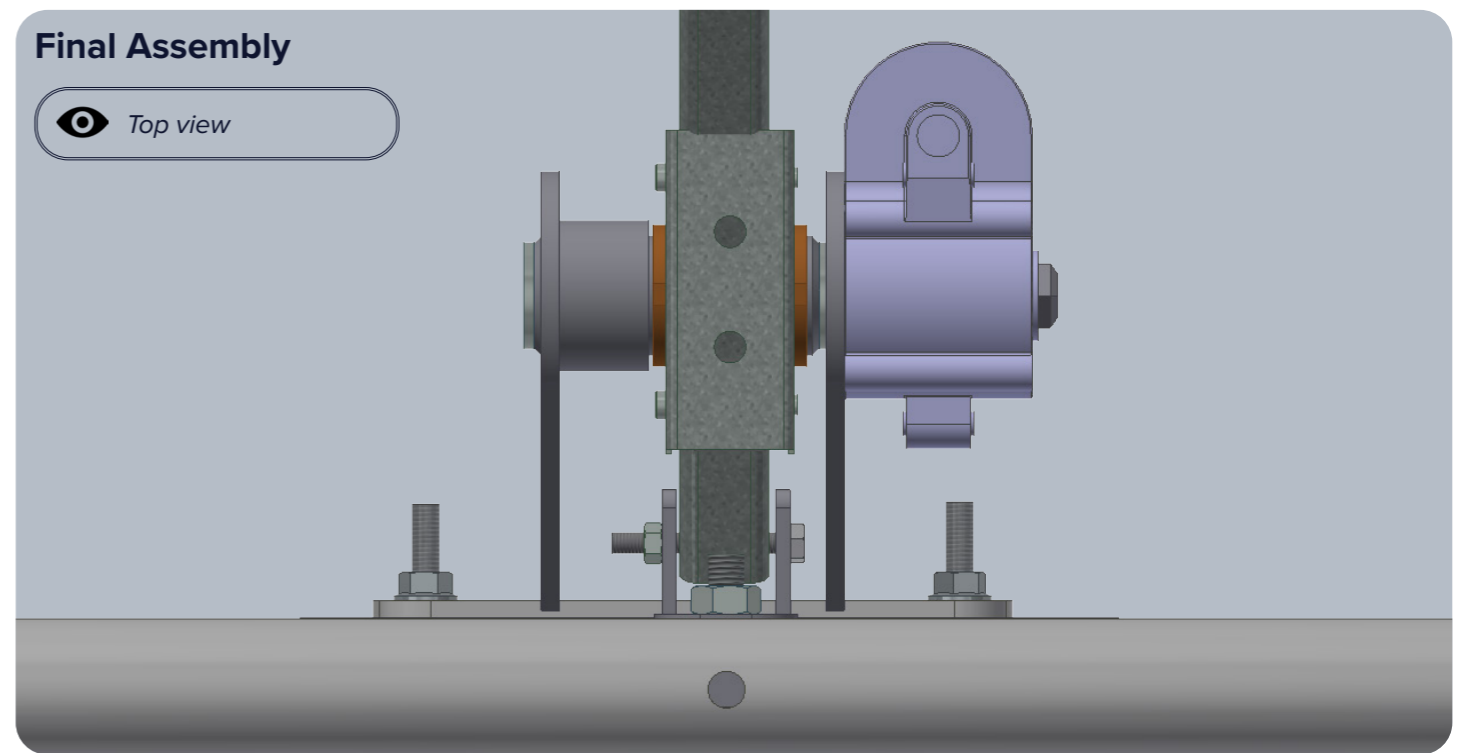

### Applying Anti Hot Spot tape

Use anti hot spot tape to cover hoops and ridge bars, as well as any sharp edges before covering your tunnel.

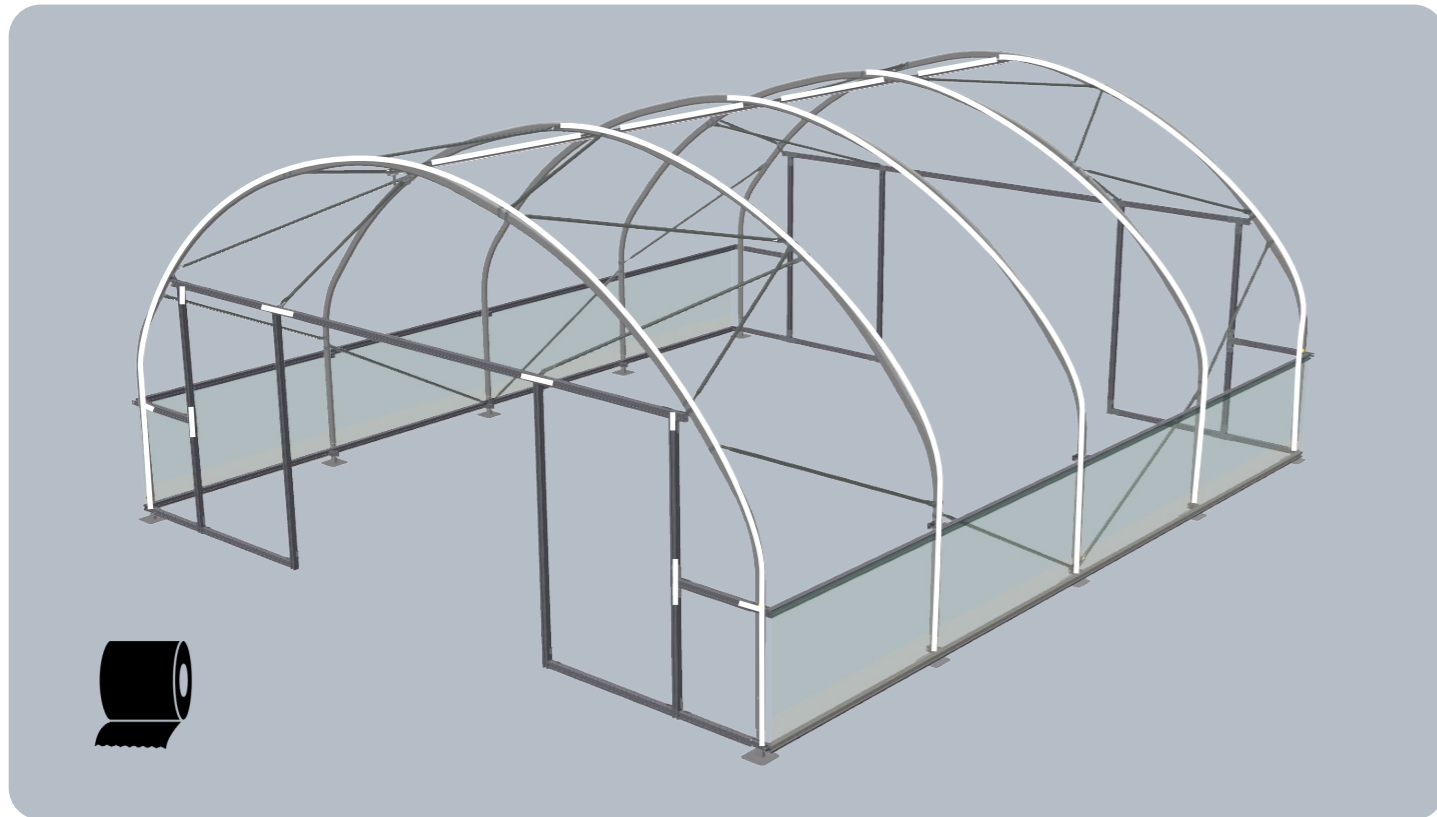

### Prepare Polythene

Unroll or unfold your polythene. Polythene is folded widthways. Ensure your polythene is the right way round - you should be able to read the text from the inside.

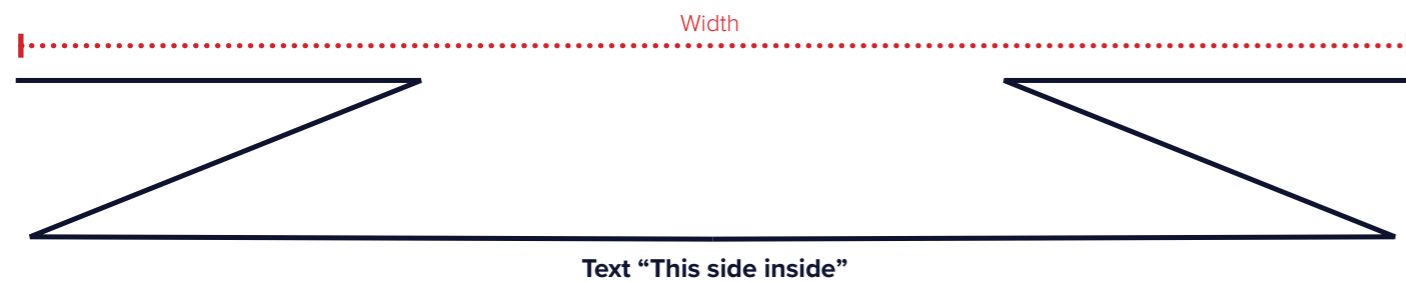

### Covering Polytunnel With Wiggle Wire Over Hoop

**!** Do not attempt if wind speed exceeds 15mph.

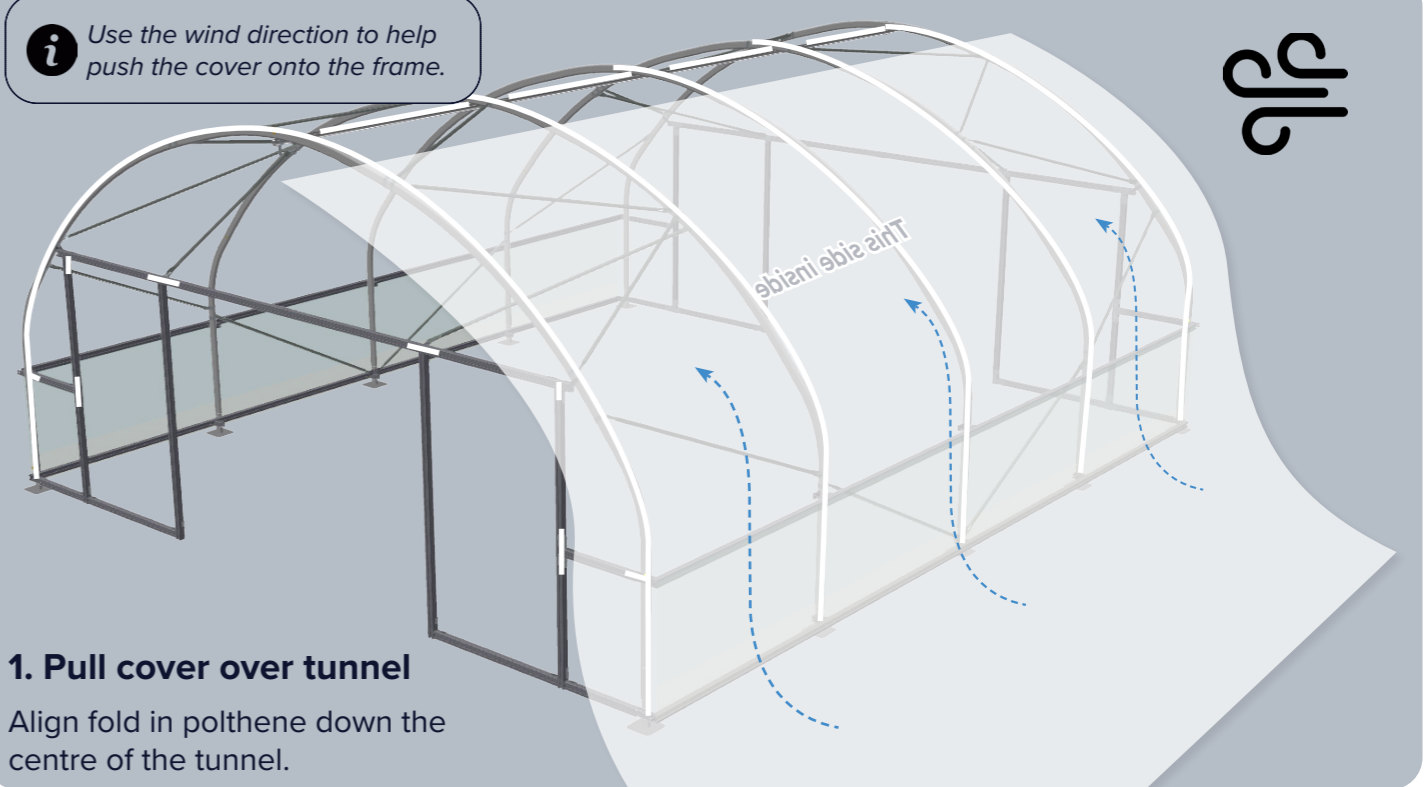

#### 1. Pull cover over tunnel

Align fold in polythene down the centre of the tunnel.

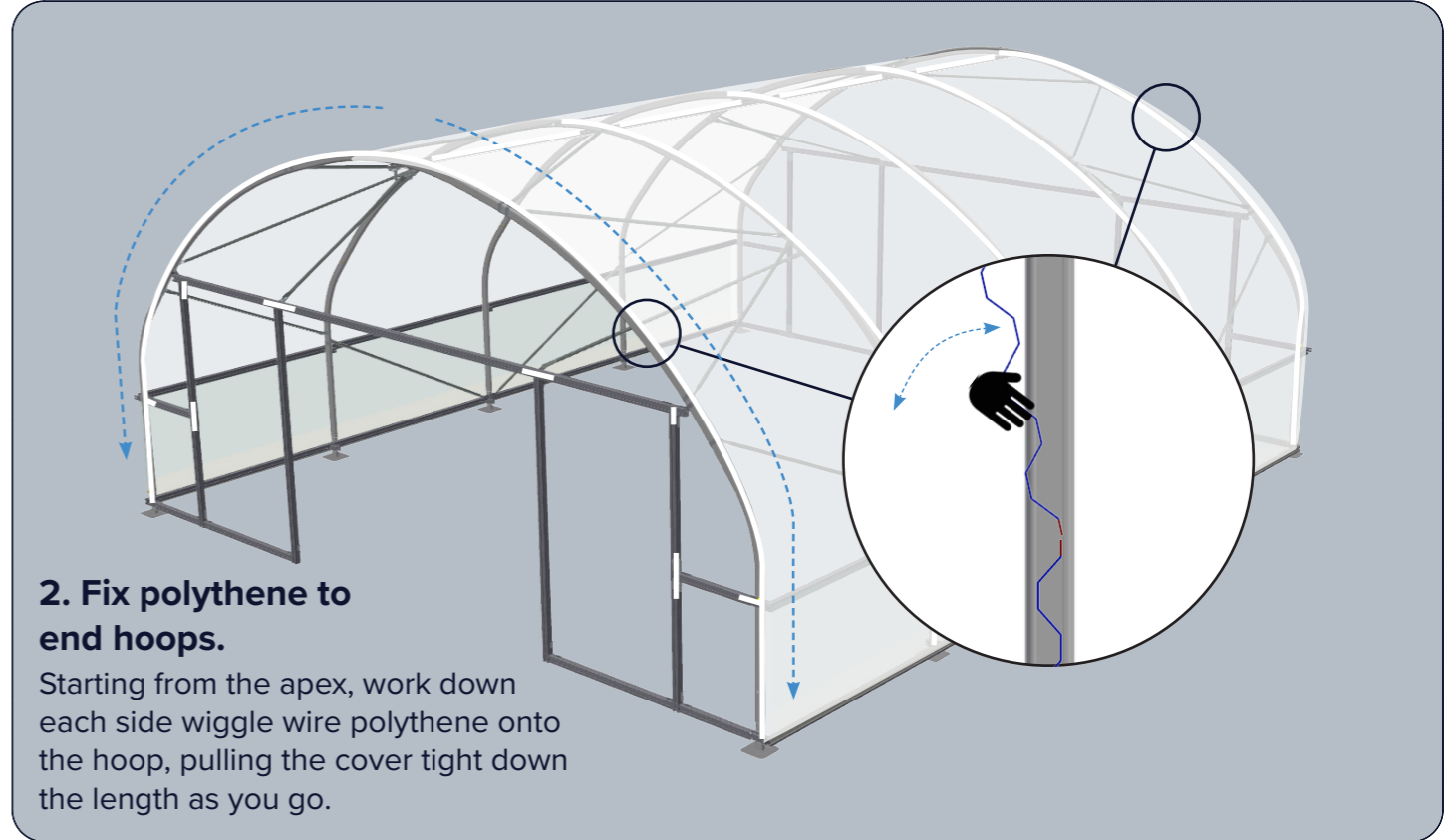

#### 2. Fix polythene to end hoops.

Starting from the apex, work down each side wiggle wire polythene onto the hoop, pulling the cover tight down the length as you go.

For "Covering Polytunnel Pleating Gable Ends Method" see page 59 >

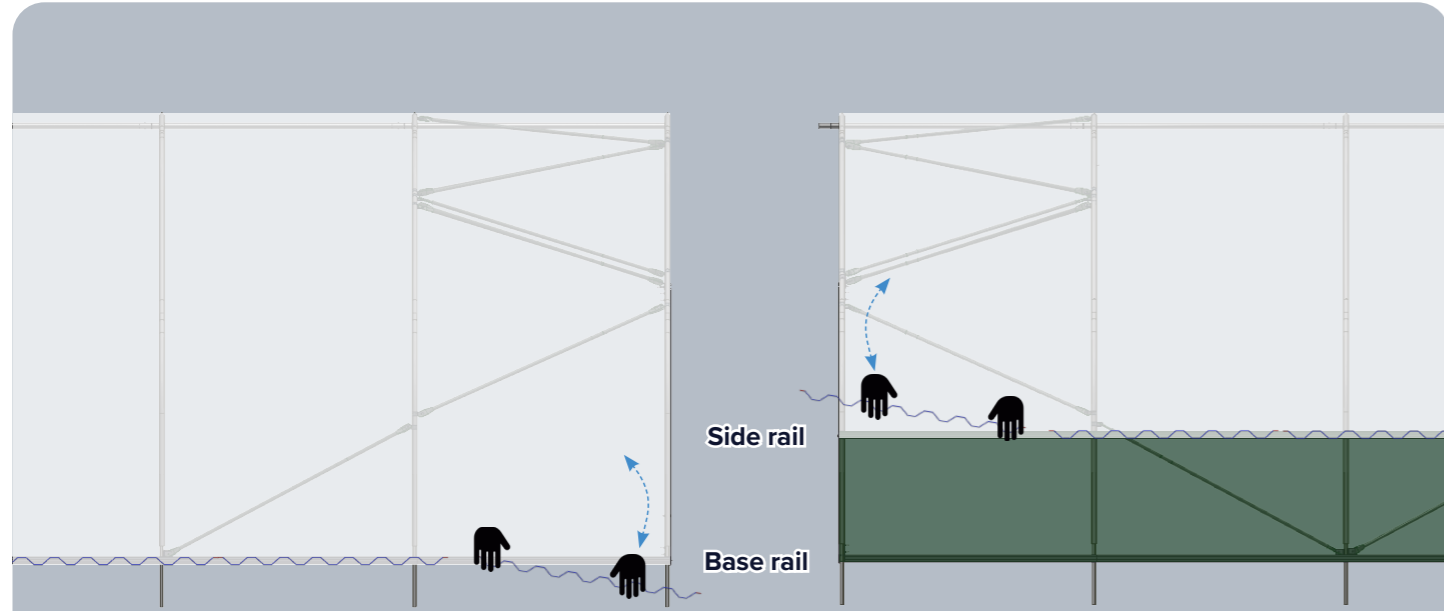

**3. Fix polythene to polytunnel sides**

For sides with vents attach to side rail.  
For sides without vents attach to base rail.  
Start from the middle and work outwards.

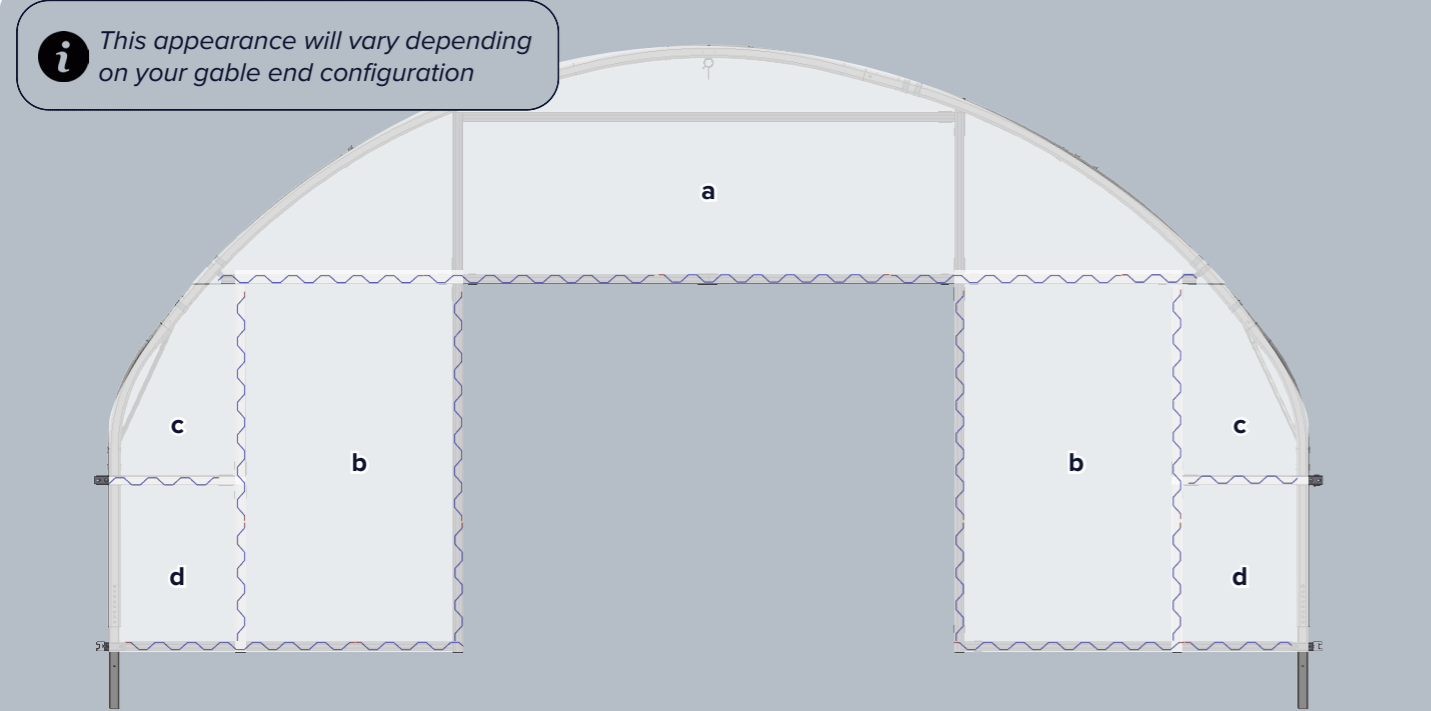

**4. Fix Gable end panels**

Cut polythene roughly to size to fit each section. Wiggle wire each piece into the gable end frame box profiles. Attach the panels to the wiggly wire channel on the hoop. Wiggle wire can be layered to accommodate multiple sheets.

*i* This appearance will vary depending on your gable end configuration

**Covering Polytunnel Pleating Gable Ends Method**

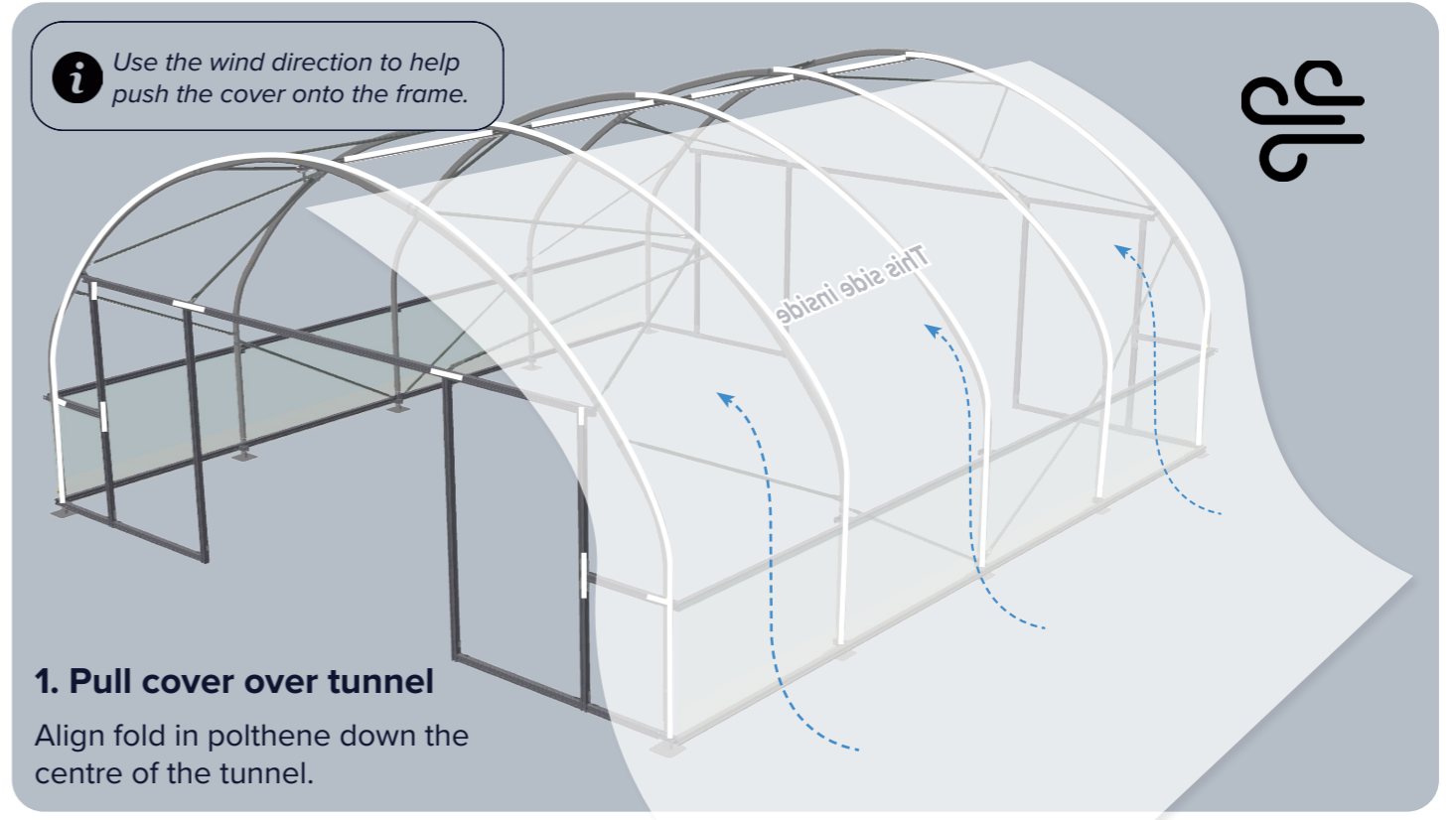

**1. Pull cover over tunnel**

Align fold in polthene down the centre of the tunnel.

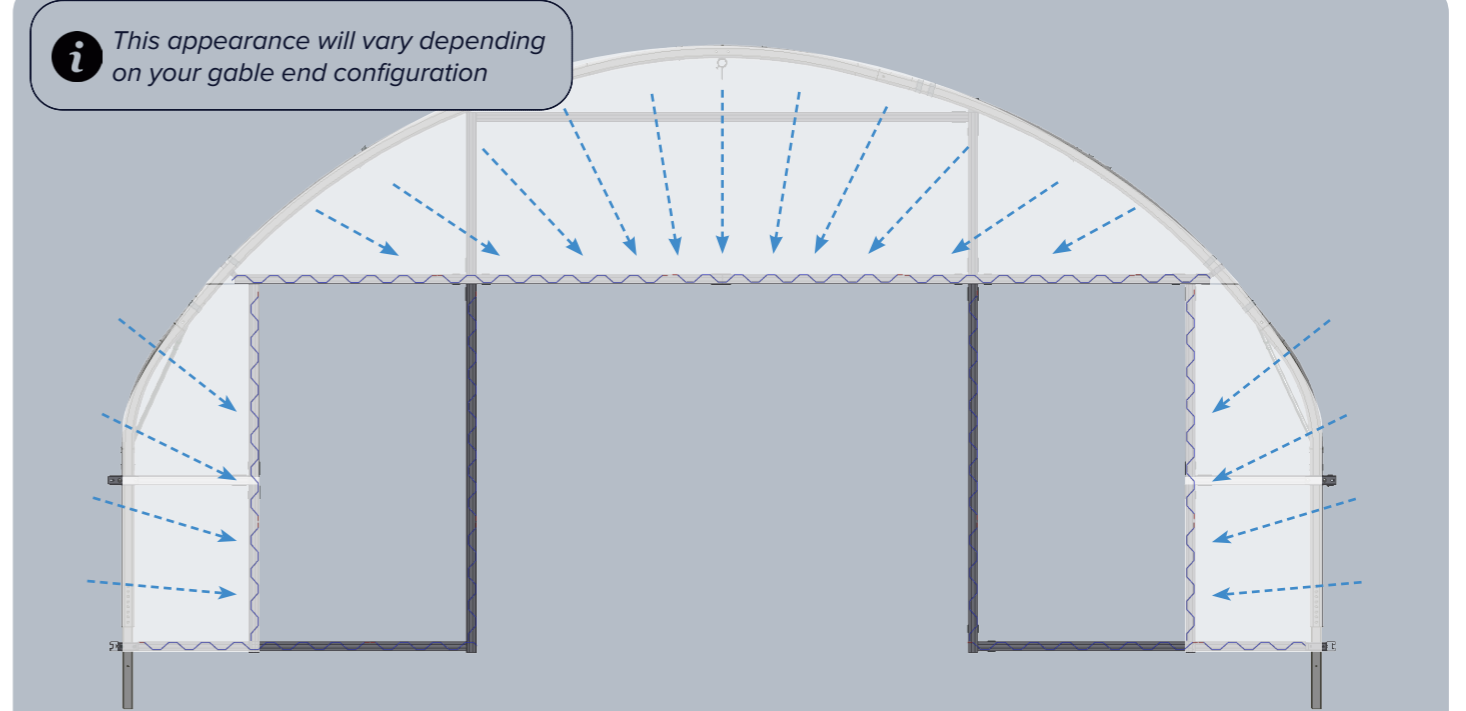

**2. Pleat cover into lintel and uprights**

Pull the polythene round the gable end and pleat neatly into the lintel and uprights.

*i* This appearance will vary depending on your gable end configuration

**i** This appearance will vary depending on your gable end configuration

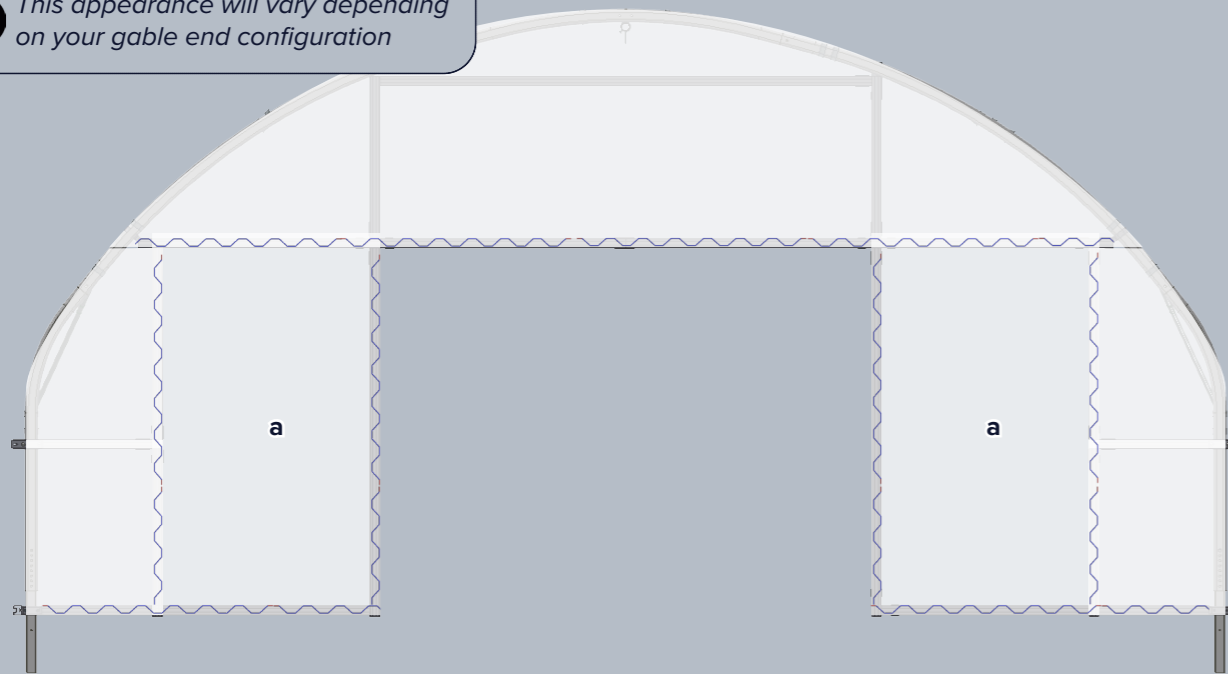

### 3. Add side panels

Cut in separate pieces to panel in at positions **a** and fix with wiggle wire.

## We're Always Looking To Improve

If you have any feedback on:

- Delivery
- Design
- Build quality
- Instructions
- Support & customer services

Please email: [marketing@npstructures.co.uk](mailto:marketing@npstructures.co.uk)

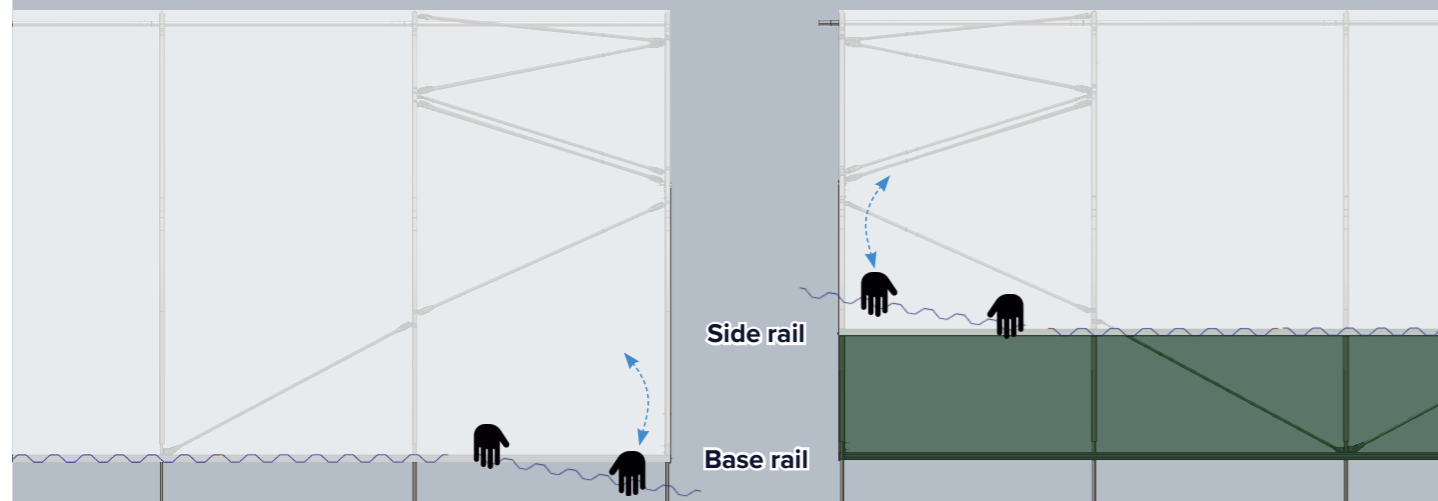

### 4. Fix polythene to polytunnel sides

For sides with vents attach to side rail.  
For sides without vents attach to base rail.  
Start from the middle and work outwards.

### Acknowledgements

Cover photos by Yousef Espanioly – Unsplash.  
Icons by Freepik, Creaticca Creative Agency, rukanicon, Lizel Arina, Smashicons, ranksol graphics, Zaenul Yahya, Gregor Cresnar, meaicon, Pixel perfect, juicy\_fish, Icongeek26, and andinur – all via Flaticon.

## Help & Advice



01282 873 120



[info@npstructures.co.uk](mailto:info@npstructures.co.uk)



[northernpolytunnels.co.uk](http://northernpolytunnels.co.uk)

