



northern
polytunnels
built to last

FIELD SHELTER

INSTRUCTION MANUAL

4m x 6m



PARTS LIST - FSR100	
ITEM	QTY PART NO DESCRIPTION
1	6 BBB501 BRACE BAR BRACKET 50MM
2	2 BBB504 BRACE BAR BRACKET DOUBLE TAB 50MM
3	4 DDB220 DIAGONAL BRACE BAR 2200MM X 31.8MM OD
4	6 EPG302 SHEET TENSIONING TUBE 1600MM X 31.8MM OD
5	4 FSR001 FIELD SHELTER 4M SWAGED HOOP 50.8MM OD
6	4 FSR002 FIELD SHELTER 4M PLAIN HOOP 50.8MM OD
7	3 FSR003 FIELD SHELTER RIDGE 1830MM HOLE-HOLE X 50.8MM OD
8	4 FSR004 FIELD SHELTER INLINE JOINT
9	4 FSR005 FIELD SHELTER CORNER JOINT
10	6 FSR006 FIELD SHELTER BASE BAR 1750MM LONG X 50.8MM OD
11	1 FSR060 FIELD SHELTER PVC SHEET 6m LONG (Green)
12	4 GFT343 SCREW ANCHOR
12a	1 SAB12 SCREW ANCHOR INSERTION BAR (INSERTS IN SCREW ANCHOR)
13	4 HTR504 RETRO HOOP TO RIDGE BRACKET 50MM/32MM
14	4 RBK025 RATCHET BUCKLE 25MM
15	6 RSP150 RATCHET STRAP 1500MM X 25MM
16a	12 RPP32 ROUND PLASTIC PLUG FOR 32MM RIDGE TUBE
16b	4 RPP50 ROUND PLASTIC PLUG FOR 50MM RIDGE TUBE

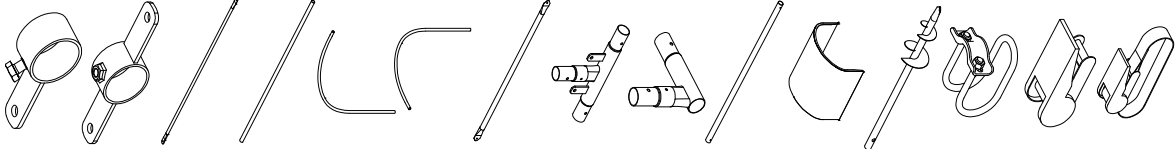

FIXINGS			
ITEM	QTY	PART NO	DESCRIPTION
17	4	HSS611	HEXAGON SETSCREW M6 X 60 MM LONG ZINC PLATE
18	4	HNN600	HEXAGON NUT NYLOCK ZINC PLATE M6
19	12	HSS810	HEXAGON SETSCREW M8 X 60 MM LONG ZINC PLATE
20	12	HNN800	HEXAGON NUT NYLOCK ZINC PLATE M8
21	14	HSS101	HEXAGON SETSCREW M10 X 20 MM LONG ZINC PLATE
22	18	HNN100	HEXAGON NUT NYLOCK ZINC PLATE M10
23	4	HBT103	HEXAGON BOLT M10 X 40 MM LONG ZINC PLATE

FITTING RECOMMENDATIONS	
TWO MAN FITTING TEAM	
STEP LADDERS	
2NO 10MM SPANNERS	
2NO 13MM SPANNERS	
2NO 17MM SPANNERS	
TAPE MEASURE	

Image shows a 4x4 field shelter design

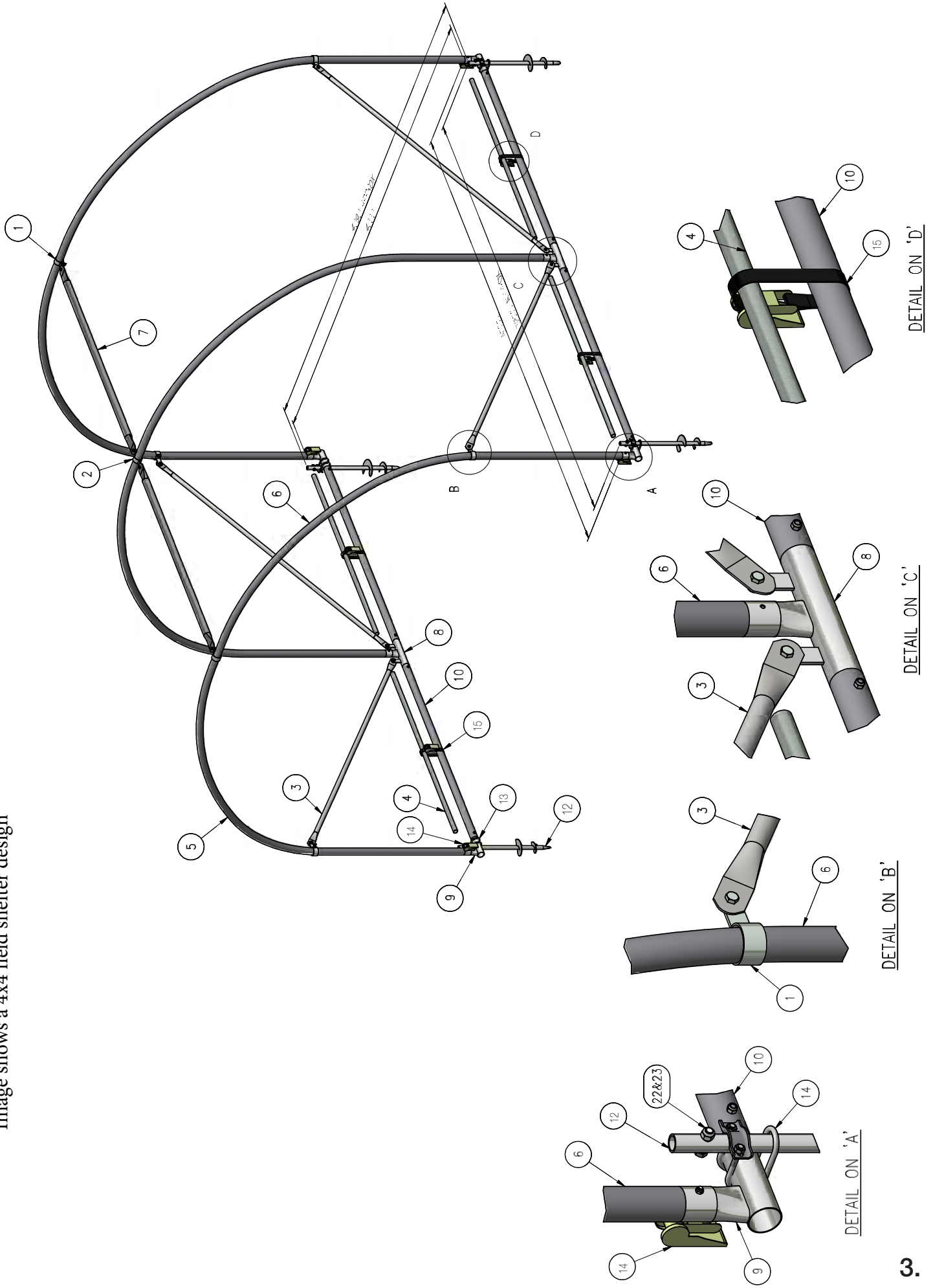

STEP 1. The Framework

Parts Required:

Item	Qty	Part No	Description
8	2	FSR004	FIELD SHELTER INLINE JOINT
9	4	FSR005	FIELD SHELTER CORNER JOINT
10	4	FSR006	FIELD SHELTER BASE BAR 1750MM LONG X 50.8MM OD

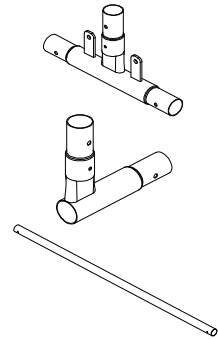

Fixings Required:

Item	Qty	Part No	Description
17	4	HSS611	HEXAGON SETSCREW M6 X 60MM LONG ZINC PLATE
18	4	HNN600	HEXAGON NUT NYLOCK ZINC PLATE M6
19	8	HSS810	HEXAGON SETSCREW M8 X 60MM LONG ZINC PLATE
20	8	HNN800	HEXAGON NUT NYLOCK ZINC PLATE M8



Assemble the base rail by connecting two base bars with an in-line joint (image 1). Securely fasten M8 bolts and nuts using two 13mm spanners/sockets etc. Fasten ratchets to corners using HSS611 and HNN600. Repeat for opposite side. Fix the number of base rails as per parts list.

STEP 2. Securing The Foundations

Parts Required:

Item	Qty	Part No	Description
12	4	GFT343	SCREW ANCHOR

13	4	HTR504	RETRO HOOP TO RIDGE BRACKET 50MM/32MM
----	---	--------	---------------------------------------

Fixings Required:

Item	Qty	Part No	Description
22	16	HNN100	HEXAGON NUT NYLOCK ZINC PLATE M10
23	4	HBT103	HEXAGON BOLT M10 X 40MM LONG ZINC PLATE

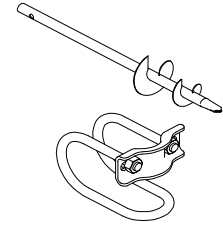
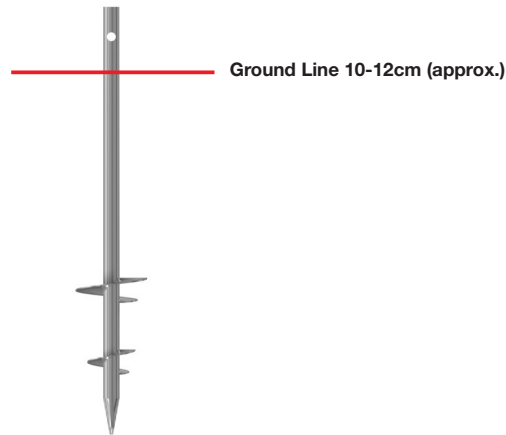

Image 4



Position two screw anchors for one side of the shelter approximately 3.8m apart, ensure any rocks and debris has been removed. Using the Screw Anchor insertion bar provided, screw the anchors into the ground. Please note: Anchors must be screwed into the ground to at least 0.55m, **inadequately secured anchors cannot provide the strength required to withstand strong winds**. If you are having an issues screwing in your anchor due to ground quality, please call us so we can advise alternative options. The flights on the screw anchors are designed to act against up-lift, this is equally relevant to downward force, with this in mind do not attempt to use a hammer to knock the anchors into the ground.



Image 5

Please note:

It is best to withhold screwing in the anchors for the opposite side until the first side is complete.

Attach the HTR504 Retro Hoop to Ridge bracket to the assembled base rail, and loop over the screw anchor (see image 5). Ensure that the anchors are on the outside of the shelter. Tighten the bolts to secure to base rail.

Finally, place a bolt through pre-drilled hole in the top of the anchor. Repeat for both corners. Failure to do this, may result in damage during high winds

STEP 3. Raising the Hoops

Parts Required:

Item	Qty	Part No	Description
5	3	FSR001	FIELD SHELTER 4M SWAGED HOOP 50.8MM OD
6	3	FSR002	FIELD SHELTER 4M PLAIN HOOP 50.8MM OD
7	2	FSR003	FIELD SHELTER RIDGE 1830MM HOLE-HOLE X 50.8MM OD
3	4	DDB220	DIAGONAL BRACE BAR 2200MM X 31.8MM OD
1	6	BBB501	BRACE BAR BRACKET 50MM
2	1	BBB504	BRACE BAR BRACKET DOUBLE TAB 50MM

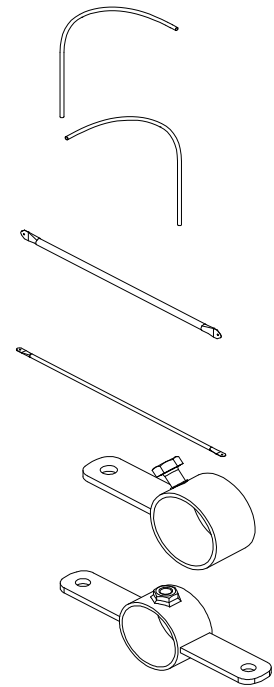

Fixings Required:

Item	Qty	Part No	Description
21	12	HSS101	HEXAGON SETSCREW M10 X 20MM LONG ZINC PLATE
22	16	HNN100	HEXAGON NUT NYLOCK ZINC PLATE M10

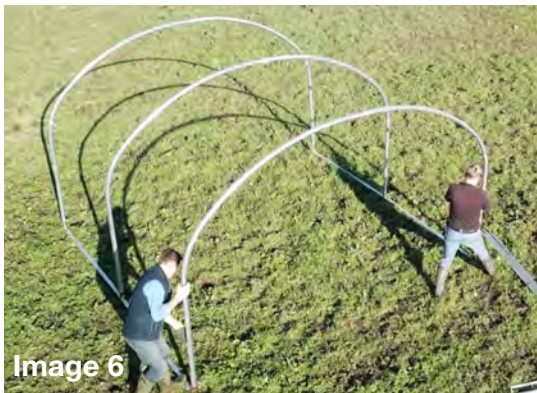

Image 6

Position the second base rail opposite the first. Couple the hoops with one swaged and one plain end facing to the centre.

End hoops

Slide 2 x brace bar bracket onto one half of the hoop and 1 x brace bar bracket onto the other half.

Centre hoops

Require 1 x brace bar bracket double tab (see diagram on page 2, Item 2).

Connect the two half hoops and insert onto the base rail.



Image 7

6. Slide one of the 2 brace bar brackets to the top centre, facing the ground. Using step ladders, secure the ridge bars to the brace bar brackets (image 7).



Image 8

Secure diagonal side struts to the brace bar brackets on the end hoops to the uprights on the base rails located at the base on the centre hoops (image 8).

STEP 4. The Cover

Parts Required:

Item	Qty	Part No	Description
11	1	FSR010	FIELD SHELTER PVC SHEET
4	4	EPG302	SHEET TENSIONING TUBE 1600MM X 31.8MM OD

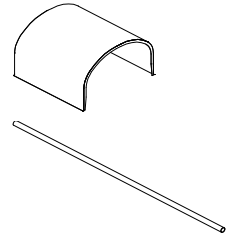

Now that the framework is complete, you can screw in the anchors for the opposite side, attaching the hoops as in Step 3.



Image 9



Image 10

Unwrap the PVC cover and pull the sheet over the hoops. A step ladder may be required. Once positioned, loop the straps through the ratchet buckles and ratchet until tensioned. Ensure that the lip of the cover is pulled over the end hoops. Repeat with all four sections.



Image 11

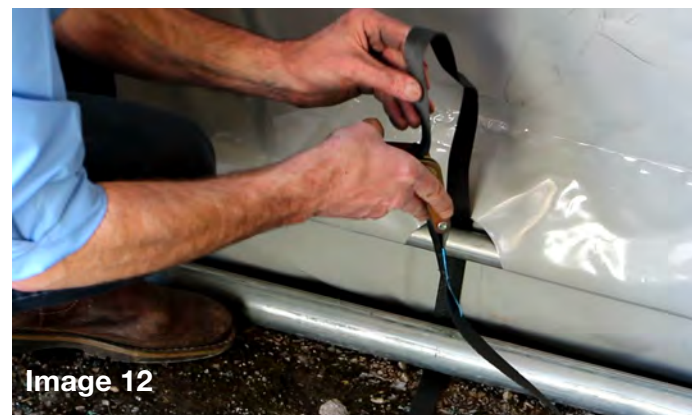

Image 12

On the inside, push the sheet tensioning tubes through the PVC pockets (image 11). Using the hole provided, loop a ratchet strap around the sheet tensioning tube and base rail (image 12). Ratchet until fully tensioned.